

2PGE and 2MGE

Cast Iron Body
Gear Pumps And Motors

Technical Catalogue

E0.146.1015.02.001M00

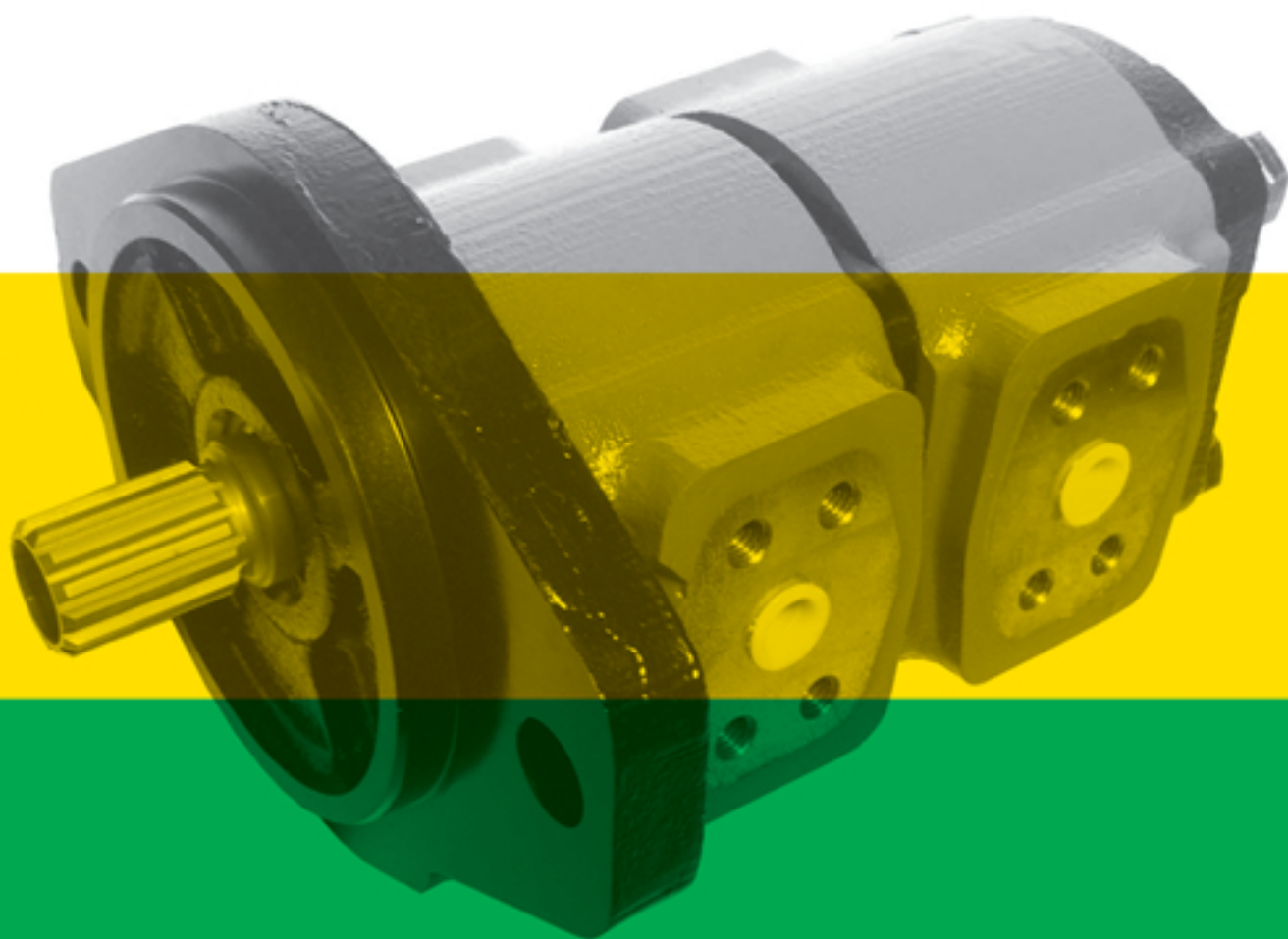

Company
with quality system
certified by DNV
UNI EN ISO 9001/2008

sajami 
FLUID POWER SYSTEMS

GENERAL INDEX

▪ Feature Gear Pumps	▪ General features ▪ Technical data ▪ Definition of pressure	Page 3
▪ Feature Gear Motors	▪ General features ▪ Technical data ▪ Definition of pressure	Page 4
▪ Drive shaft ▪ Pumps and motors rotation		Page 5
▪ Hydraulic pipe line ▪ Filtration index recommended ▪ Fire resistant fluid ▪ Common formulas for pumps and motors		Page 6
▪ Combination with types of flanges and drives shafts		Page 7
▪ Working conditions gear pumps ▪ Assembling dimensions		Page 8
▪ Working conditions gear motors ▪ Assembling examples		Page 9
▪ Flanged ports		Page 10
▪ Threaded ports		Page 12
▪ Drive shafts		Page 13
▪ Mounting flanges		Page 14
▪ Outrigger bearing		Page 16
▪ Mounting flanges with outrigger bearing support		Page 17
▪ Rear covers		Page 18
▪ Rear covers with internal and lateral drain ▪ Rear covers with main relief valves		Page 19
▪ Priority flow valve		Page 20
▪ Multiple gear pumps assembling dimensions ▪ Multiple gear pumps with separated stages		Page 23
▪ Pumps performance curves		Page 24
▪ Motors performance curves		Page 26
▪ How to order 2PGE-2MGE		Page 28

EO.146.1015.02.00IM00

E0.146.1015.02.00IM00

The data in this catalogue refers to the standard product.

The policy of Salami S.p.A. consists of a continuous improvement of its products. It reserves the right to change the specifications of the different products whenever necessary and without giving prior information.

If any doubts, please get in touch with our sales department.



GENERAL FEATURES

SALAMI gear pumps are available with displacements from 16 cm³/rev to 26 cm³/rev (*from 1.01 cu.in./rev to 1.58 cu.in./rev*).

All pumps are available as multiple units either of the same or different series.

With all sizes of pumps there are options of shafts, flanges and ports as for European, German and American standards.

SALAMI gear pumps offer:

- High volumetric efficiency by innovative design and accurate control of machining tolerances.
 - Axial compensation achieved by the use of floating bushes that allow high volumetric efficiency throughout the working pressure range.
 - DU bearings ensure high pressure capability.
 - 12 teeth integral gear and shaft.
 - Cast iron body.
 - Cast iron flange and cover.
 - Double shaft seals.
 - Nitrile seals as standard and Viton seals in high temperature applications.
 - Typical 2PGE gear pumps are ideal for mobile equipment including: snow plows, light duty equipment, lift trucks, farm vehicles, town trucks, cherry pickers, lift gates, utility vehicles, aerial devices, hoists, spreaders, fan drive.
- All pumps are hydraulic tested after assembly to ensure the high standard performance required by SALAMI'S engineering.

TECHNICAL DATA

- Pump inlet pressure (absolute pressure)	0.8 to 1.5 bar (11.6 to 21.7 psi)
- Minimum operating fluid viscosity	12 mm ² / sec
- Max starting viscosity	800 mm ² / sec
- Suggested fluid viscosity range	17 - 65 mm ² / sec
- Fluid operating temperature range	-25 to 85 °C
- Fluid operating temperature range with FPM seals(Viton)	-20 to 110°C
- Hydraulic fluid	mineral oil

Important:

in case of assembling of pumps without shaft seals (eg. B4 - B5...), you have to keep the value of min. suction pressure (0.8 bar (abs)) in the vane between pump and coupling too.

Lower pressure can lead to suction of oil through the front flange (seat of the shaft without seal); this can damage seriously the pump.

DEFINITION OF PRESSURES

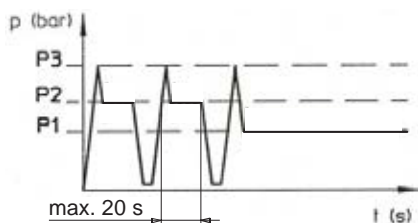

P3 = Peak pressure

P2 = Intermittent operating pressure (1/3 of working time)

P1 = Continuous operating pressure

EO.146.1015.02.001M00



GENERAL FEATURES

- Displacements from 16 cm³/rev to 26 cm³/rev (from 1.01 cu.in./rev to 1.58 cu.in./rev).
- Rated pressure up to 250 bar (3625psi).
- Back pressure capability up to 120 bar (1740 psi) only in bi-directional release.
- Speed up to 3200 rpm.
- Flanges, shafts and ports for ISO, DIN and SAE standards.
- Available in uni and bi-directional version for all the frame sizes, displacements and configurations.
- High volumetric efficiency by innovative design and accurate control of machining tolerances.
- Axial compensation achieved by the use of floating bushes that allow high volumetric efficiency throughout the working pressure range.
- DU bearings ensure high pressure capability.
- 12 teeth integral gear and shaft.
- Cast iron body.
- Cast iron flange and cover.
- Double shaft seals in all motor series. The one which faces the internal side is reinforced.
- Nitrile seals as standard and Viton seals in high temperature applications.
- Available with different valves and circuit configurations built-in rear cover.
- All motors are hydraulic tested after assembly to ensure the high standard performance required.
- Typical 2MGE gear motors are ideal for mobile equipment including: snow plows, light duty equipment, farm vehicles, town trucks, cherry pickers, lift gates, utility vehicles, aerial devices, hoists, spreaders, fan drive.

TECHNICAL DATA

- Minimum operating fluid viscosity	12 mm ² /sec
- Permitted viscosity range	12 - 800 mm ² / sec
- Recommended viscosity range	20 - 80 mm ² / sec
- Permitted viscosity for starting	2000 mm ² / sec
- Fluid operating temperature range	-25 to 85 °C
- Fluid operating temperature range with FPM seals	-20 to 110°C
- Hydraulic fluid	mineral oil

DEFINITION OF PRESSURES

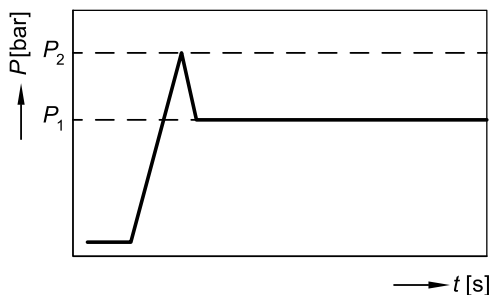

P_1 max. continuous pressure
 P_2 starting pressure (depending on the application, this must be taken into consideration when setting the pressure of the hydraulic system's pressure-relief valve).

DRIVE SHAFTS

Radial and axial loads on the shafts must be avoided since they reduce the life of the unit.
 In order to avoid misalignment during the assembly with the primary engine, a connection with "Oldham" coupling (or coupling having convex toothed hub) is recommended.

PUMP AND MOTOR ROTATION DIRECTION VIEWED AT THE DRIVE SHAFT

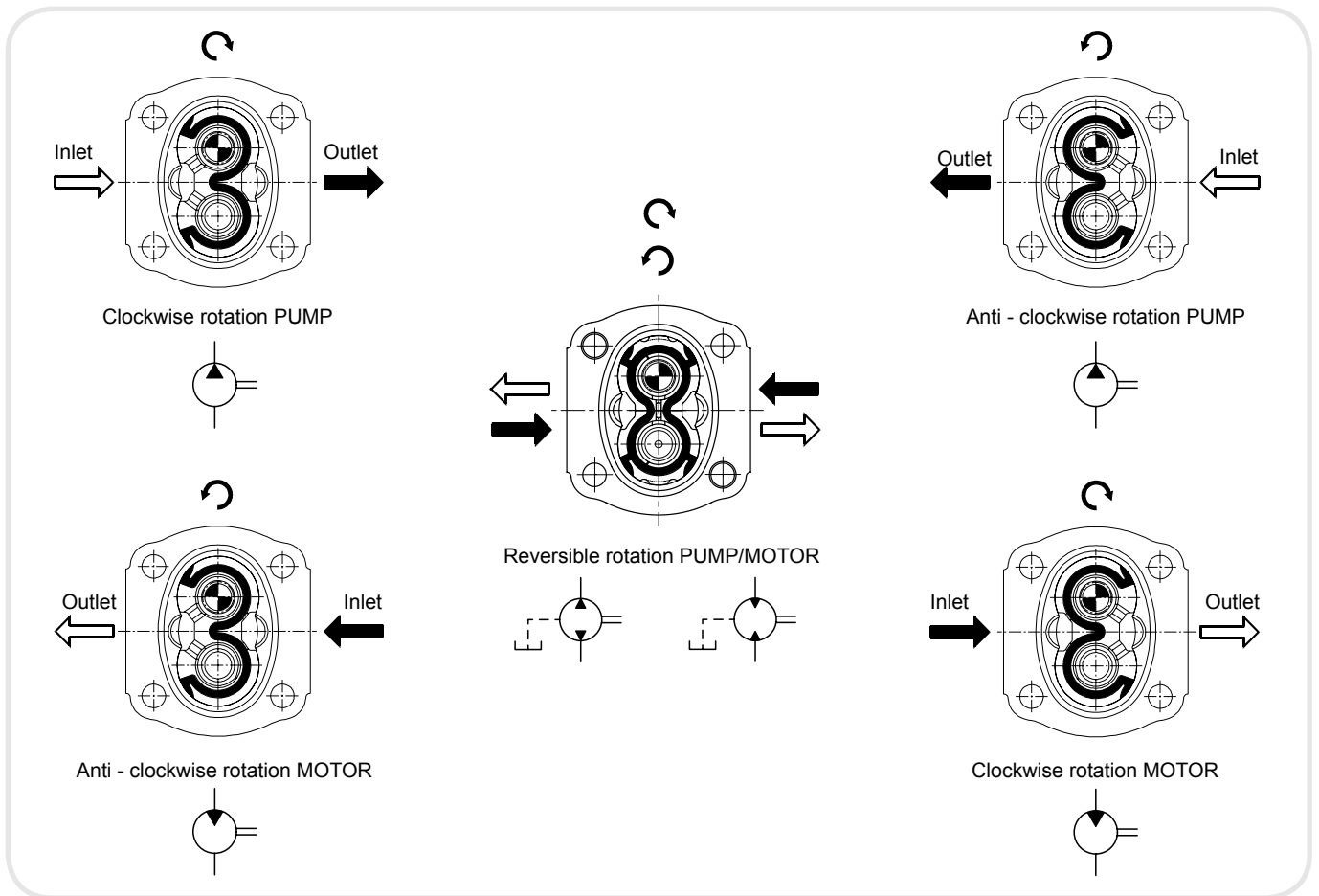

EO.146.1015.02.001M00



HYDRAULIC PIPE LINE

To ensure favorable suction conditions it is important to keep pressure drop in suction pipe line to a minimum value (see TECHNICAL DATA).

To calculate hydraulic pipe line size, the designer can use; as an approximate guide, the following fluid speed figures:

From 1 to 2 m/sec on suction pipe line
From 6 to 10 m/sec on pressure pipe line

From 3.28 to 6.36 ft/sec on suction pipe line
From 19.7 to 32.8 ft/sec on pressure pipe line

The lowest fluid speed values in pipe lines is recommended when the operating temperature range is high and/or for continuous duty.

The highest value is recommended when the temperature difference is low and/or for intermittent duty.

When tandem pumps are supplied by 2 different reservoirs with 2 different fluids it is necessary to specify "AS" version.

In case of reversible motor allowance must be made to ensure the motor is not drained, through the case drain, when stationary.

FILTRATION INDEX RECOMMENDED

Working pressure	>200 bar/2900 psi	<200 bar/2900 psi
Contamination class NAS 1638	9	10
Contamination class ISO 4406	18/15	19/16
Achieved with filter $\beta_x=75$	15 μm	25 μm

FIRE RESISTENT FLUID

Type	Description	Max pressure	Max speed (rpm)	Temperature
HFB	Oil emulsion with 40% water	130 bar/1880 psi	2500	3°C+65°C
HFC	Water glycol	180 bar/2600 psi	1500	-20°C+65°C
HFD	Phosphate esters		1750	-10°C+80°C

COMMON FORMULAS FOR PUMPS

$$C = \text{Input torque} = \frac{q \cdot \Delta p}{62.8 \cdot \eta_m} \text{ (Nm)}$$

$$P = \text{Input power} = \frac{q \cdot n \cdot \Delta p \cdot 10^{-3}}{600 \eta_m} \text{ (kW)}$$

$$Q = \text{Outlet flow} = \frac{q \cdot n \cdot \eta_v}{1000} \text{ (l/min)}$$

LEGENDA

Δp = Working pressure (bar)

q = Displacement (cm^3/rev)

n = Speed (min^{-1})

η_m = Mechanical eff. (0.92)

η_v = Volumetric eff. (0.95)

COMMON FORMULAS FOR MOTORS

$$\text{Input flow: } Q = \frac{V \cdot n}{1000 \cdot \eta_v} \text{ l/min}$$











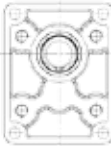

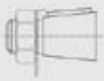

$$\text{Output torque: } M = \frac{V \cdot \Delta p \cdot \eta_m}{20 \cdot \pi} \text{ Nm}$$

$$\text{Output power: } P = \frac{M \cdot n}{9550} = \frac{Q \cdot \Delta p \cdot \eta_l}{600} \text{ kW}$$

V = Displacement cm^3/rev [in^3/rev]
 P_{out} = Outlet pressure bar [psi]
 P_{in} = Inlet pressure bar [psi]
 ΔP = $P_{out} - P_{in}$ (system pressure) bar [psi]
 n = Speed min^{-1} (rpm)
 η_v = Volumetric efficiency
 η_m = Mechanical efficiency
 η_l = Overall efficiency ($\eta_v \cdot \eta_m$)

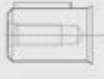

**COMBINATION WITH TYPES OF FLANGES
AND DRIVES SHAFTS AVAILABLE**

2PGE 2MGE	 P1	 B1	 B4 B5	 S2	 C1	 S3
 25		25 B1	25 B4 25 B5			
 28	28 P1					
 62	62 P1	62 B1	62 B4 62 B5		62 C1	
 52				52 S2		
 54				54 S2		
 55						55 S3
 85				85 S2		
 82	82 P1			82 S2		

Note: other versions available, see shafts and flanges information.

EO.146.1015.02.001M00



Displacements up to 1.58 cu.in./rev
Pressure up to 4350 psi

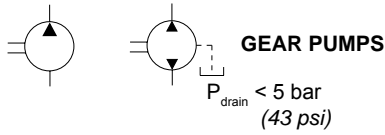

Displacements up to 25.8 cm³/rev
Pressure up to 300 bar

WORKING CONDITIONS GEAR PUMPS

Type			16	19	22.5	26
Displacement		cm ³ /rev cu.in./rev	16.6 1.01	19.4 1.18	22.9 1.37	25.8 1.58
Dimension A		mm in	67.5 2.65	75.6 2.97	81 3.19	86.8 3.42
Dimension C		mm in	39.5 1.56	39.5 1.56	47.5 1.87	47.5 1.87
Continuous pressure	p1	bar psi	250 (3600)		230 (3335)	220 (3140)
Intermittent pressure	p2	bar psi	280 (4061)		260 (3750)	240 (3480)
Peak pressure	p3	bar psi	300 (4351)		280 (4061)	260 (3750)
Max speed at	p2	rpm	3000		2750	2500
Min speed at	p1	rpm	500		500	500
Weight		kg lbs	6.6 14.5	7.1 15.6	7.5 16.5	7.8 17.2

ASSEMBLING DIMENSIONS

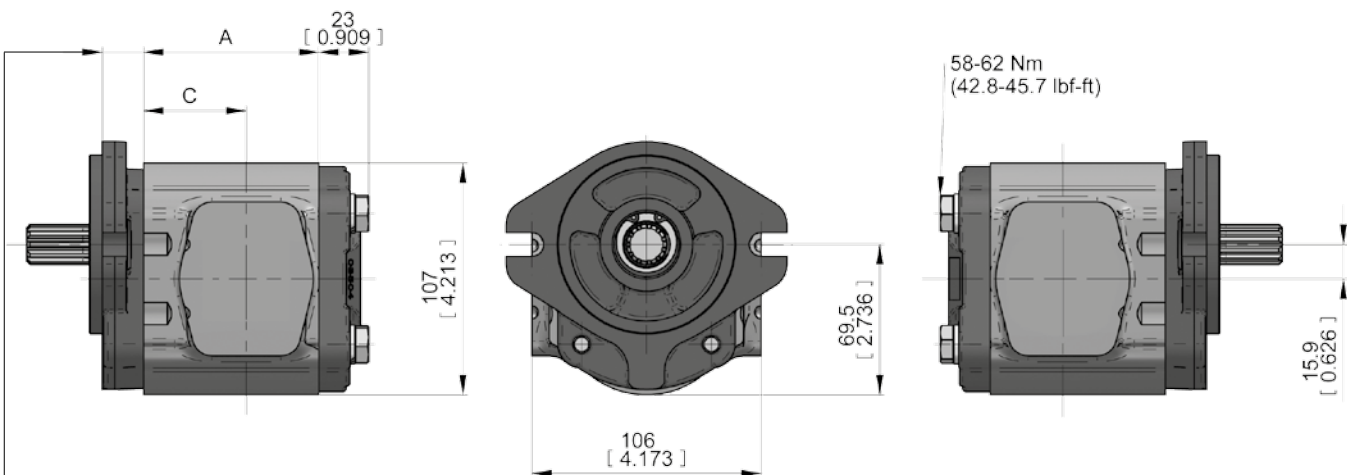

For flanges code:
P1-B1-S2-S3, this dimension is 19 mm (0.75 in.)
B4-B5-C1, this dimension is 16.5 mm (0.65 in.)

E0.146.1015.02.00IM00



Displacements up to 1.58 cu.in./rev
Pressure up to 4000 psi

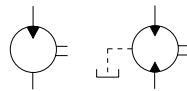

GEAR MOTORS

Displacements up to 25.8 cm³/rev
Pressure up to 280 bar

WORKING CONDITIONS GEAR MOTORS

Group 2		16	19	22.5	26
Type		16	19	22.5	26
max. continuous pressure P ₁	bar (psi)	250 (3600)	220 (3140)	200 (2900)	180 (2600)
max. starting pressure P ₂		280 (4000)	240 (3450)	220 (3140)	200 (2900)
min. rotational speed	min ⁻¹	450			
max. rotational speed P ₁		3200		3000	2850
Motor outlet pressure P _{out} Leakage-oil line pressure P _{drain}	bar (psi)				

ASSEMBLING EXAMPLES



2PGE - B25B1

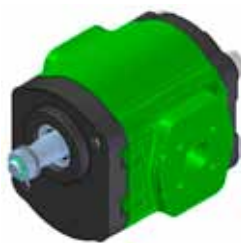

2PGE - B25B4



2PGE - P28P1



2PGE - R54S2

EO.146.1015.02.001M00



FLANGED PORTS

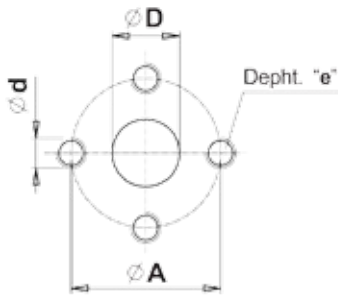

code P

Flanged ports
european standard

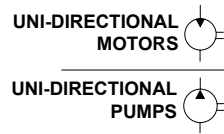

TYPE	OUTLET				INLET			
	Ø D	Ø A	d	e	Ø D	Ø A	d	e
From 16 to 22.5	20 0.79	40 (1.57")	M8	13 (0.51")	13 (0.51")	30 (1.18")	M6	13 (0.51")
26	22 0.87							



TYPE	INLET				OUTLET			
	Ø D	Ø A	d	e	Ø D	Ø A	d	e
16	13 (0.51")	30 (1.18")	M6	13 (0.51")	13 (0.51")	30 (1.18")	M6	13 (0.51")
From 19 to 26	20 (0.79")	40 (1.57")	M8	13 (0.51")	20 (0.79")	40 (1.57")	M8	13 (0.51")



TYPE	INLET				OUTLET			
	Ø D	Ø A	d	e	Ø D	Ø A	d	e
From 16 to 26	20 (0.79")	40 (1.57")	M8	13 (0.51")	20 (0.79")	40 (1.57")	M8	13 (0.51")

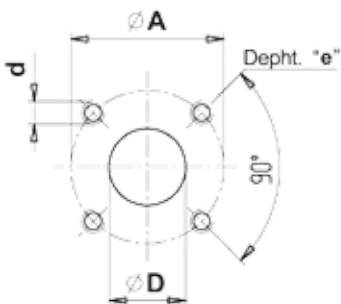

code B

Flanged ports
german standard

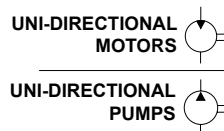

TYPE	OUTLET				INLET			
	Ø D	Ø A	d	e	Ø D	Ø A	d	e
From 16 to 22.5	20 0.79	40 (1.57")	M6	13 (0.51")	15 (0.59")	35 (1.38")	M6	13 (0.51")
26	22 0.87							



TYPE	INLET				OUTLET			
	Ø D	Ø A	d	e	Ø D	Ø A	d	e
16	15 (0.59")	35 (1.38")	M6	13 (0.51")	15 (0.59")	35 (1.38")	M6	13 (0.51")
From 19 to 26	20 (0.79")	40 (1.57")	M6	13 (0.51")	20 (0.79")	40 (1.57")	M6	13 (0.51")



TYPE	INLET				OUTLET			
	Ø D	Ø A	d	e	Ø D	Ø A	d	e
From 16 to 26	20 (0.79")	40 (1.57")	M6	13 (0.51")	20 (0.79")	40 (1.57")	M6	13 (0.51")

E0.146.1015.02.00IM00



UNI-DIRECTIONAL MOTORS

UNI-DIRECTIONAL PUMPS

TYPE	OUTLET					INLET				
	ØD	B	A	d	e	ØD	B	A	d	e
From 16 to 19	19 (0.75")	47.6 (1.87")	22.2 (0.87")	M10	15 (0.59")	12.7 (0.50")	38.1 (1.50")	17.5 (0.69")	M8	15 (0.59")
From 22.5 to 26	25.4 (1.00")	52.4 (2.06")	26.2 (1.03")	M10	15 (0.59")	19 (0.75")	47.6 (1.87")	22.2 (0.87")	M10	15 (0.59")

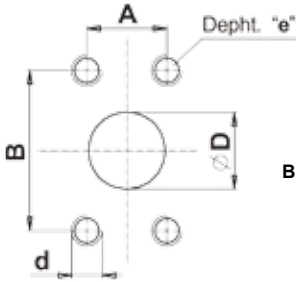

code W

Flanged ports
SAE J518
METRIC THREAD

BI-DIRECTIONAL MOTORS

TYPE	INLET					OUTLET				
	ØD	B	A	d	e	ØD	B	A	d	e
16	12.7 (0.50")	38.1 (1.50")	17.5 (0.69")	M8	15 (0.59")	12.7 (0.50")	38.1 (1.50")	17.5 (0.69")	M8	15 (0.59")
From 22.5 to 26	19 (0.75")	47.6 (1.87")	22.2 (0.87")	M10	15 (0.59")	19 (0.75")	47.6 (1.87")	22.2 (0.87")	M10	15 (0.59")

BI-DIRECTIONAL PUMPS

TYPE	INLET					OUTLET				
	ØD	B	A	d	e	ØD	B	A	d	e
From 16 to 26	19 (0.75")	47.6 (1.87")	22.2 (0.87")	M10	15 (0.59")	19 (0.75")	47.6 (1.87")	22.2 (0.87")	M10	15 (0.59")

UNI-DIRECTIONAL MOTORS

UNI-DIRECTIONAL PUMPS

TYPE	OUTLET					INLET				
	ØD	B	A	d	e	ØD	B	A	d	e
From 16 to 19	19 (0.75")	47.6 (1.87")	22.2 (0.87")	3/8-16 UNC	15 (0.59")	12.7 (0.50")	38.1 (1.50")	17.5 (0.69")	5/16-18 UNC	15 (0.59")
From 22.5 to 26	25.4 (1.00")	52.4 (2.06")	26.2 (1.03")	3/8-16 UNC	15 (0.59")	19 (0.75")	47.6 (1.87")	22.2 (0.87")	3/8-16 UNC	15 (0.59")

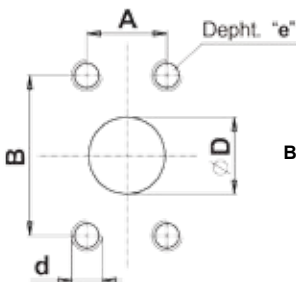

code S

Flanged ports
SAE J518
AMERICAN STANDARD
THREAD

BI-DIRECTIONAL MOTORS

TYPE	INLET					OUTLET				
	ØD	B	A	d	e	ØD	B	A	d	e
16	12.7 (0.50")	38.1 (1.50")	17.5 (0.69")	5/16-18 UNC	15 (0.59")	12.7 (0.50")	38.1 (1.50")	17.5 (0.69")	5/16-18 UNC	15 (0.59")
From 22.5 to 26	19 (0.75")	47.6 (1.87")	22.2 (0.87")	3/8-16 UNC	15 (0.59")	19 (0.75")	47.6 (1.87")	22.2 (0.87")	3/8-16 UNC	15 (0.59")

BI-DIRECTIONAL PUMPS

TYPE	INLET					OUTLET				
	ØD	B	A	d	e	ØD	B	A	d	e
From 16 to 26	19 (0.75")	47.6 (1.87")	22.2 (0.87")	3/8-16 UNC	15 (0.59")	19 (0.75")	47.6 (1.87")	22.2 (0.87")	3/8-16 UNC	15 (0.59")

EO.146.1015.02.00IM00



THREADED PORTS

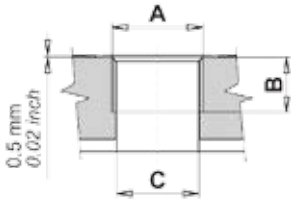

code G

Threaded ports
GAS (BSPP)

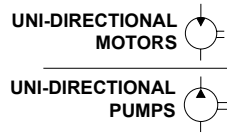

TYPE	OUTLET			INLET		
	A	B	C	A	B	C
From 16 to 19	G 3/4	17 (0.67")	20 (0.79")	G 1/2	15 (0.59")	13 (0.79")
From 22.5 to 26	G1	22 (0.87")	25 (0.98")			



TYPE	INLET			OUTLET		
	A	B	C	A	B	C
16	G 1/2	15 (0.59")	13 (0.79")	G 1/2	15 (0.59")	13 (0.79")
From 19 to 26	G 3/4	17 (0.67")	20 (0.79")	G 3/4	17 (0.67")	20 (0.79")



TYPE	INLET			OUTLET		
	A	B	C	A	B	C
From 16 to 26	G 3/4	17 (0.67")	20 (0.79")	G 3/4	17 (0.67")	20 (0.79")

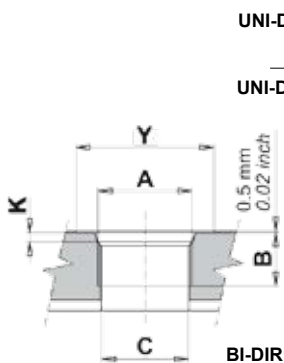

code R

Threaded ports
SAE (ODT)

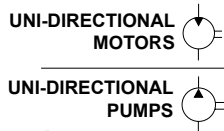

TYPE	OUTLET					INLET				
	A	B	C	Y	K	A	B	C	Y	K
From 16 to 19	1-1/16-12 UN (SAE 12)	19 (0.75")	20 (0.79")	41 (1.61")	3.3 (0.13")	7/8-14 UNF (SAE 10)	17 (0.67")	13 (0.79")	34 (1.32")	2.5 (0.10")
From 22.5 to 26	1-5/16-12 UN (SAE 16)	19 (0.75")	25 (0.98")	49 (1.93")	3.3 (0.13")					



TYPE	INLET					OUTLET				
	A	B	C	Y	K	A	B	C	Y	K
16	7/8-14 UNF (SAE 10)	17 (0.67")	13 (0.79")	34 (1.32")	2.5 (0.10")	7/8-14 UNF (SAE 10)	17 (0.67")	13 (0.79")	34 (1.32")	2.5 (0.10")
From 19 to 26	1-1/16-12 UN (SAE 12)	19 (0.75")	20 (0.79")	41 (1.61")	3.3 (0.13")	1-1/16-12 UN (SAE 12)	19 (0.75")	20 (0.79")	41 (1.61")	3.3 (0.13")



TYPE	INLET					OUTLET				
	A	B	C	Y	K	A	B	C	Y	K
From 16 to 26	1-1/16-12 UN (SAE 12)	19 (0.75")	20 (0.79")	41 (1.61")	3.3 (0.13")	1-1/16-12 UN (SAE 12)	19 (0.75")	20 (0.79")	41 (1.61")	3.3 (0.13")

E0.146.1015.02.00IM00



DRIVE SHAFTS

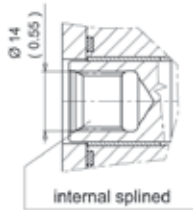
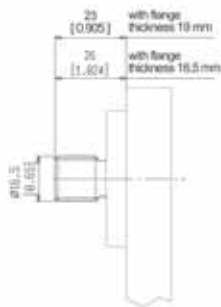

Key 3,96x3,96x12,7



The dimension 31,8, is referred to flange thickness 19. In case of flange thickness 16,5, please contact our sales dept.

Key 4,78x4,78x12,7

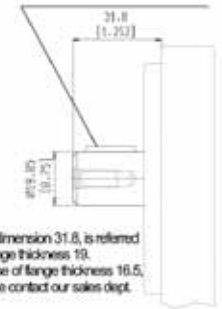

The dimension 31,8, is referred to flange thickness 19. In case of flange thickness 16,5, please contact our sales dept.

code 62 Max torque 125 Nm
9 teeth DIN 5482 splined

code 60 Max torque 110 Nm
DIN 5480 internal splined

code 82 Max torque 75 Nm
5/8" SAE A parallel

code 85 Max torque 125 Nm
3/4" SAE A parallel

Only for rear pumps

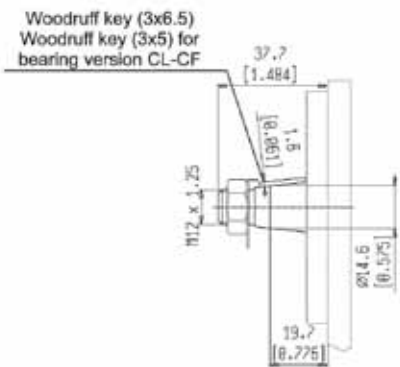

code 25 Max torque 130 Nm
Tapered 1:5



code 26 Max torque 110 Nm
Tapered 1:5 (only for CB)

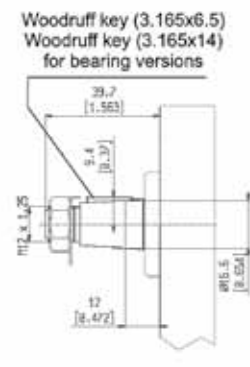

code 28 Max torque 130 Nm
Tapered 1:8

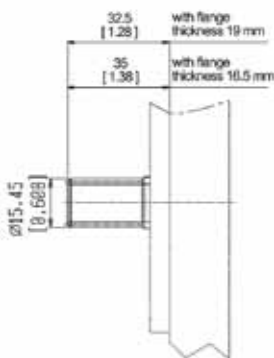

code 52 Max torque 110 Nm
SAE A 9T-16/32DP Ansi B92 1a 1976

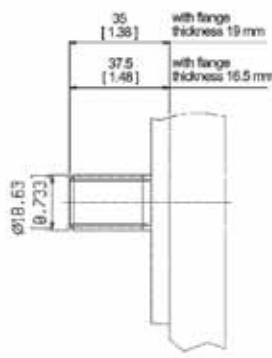

code 54 Max torque 160 Nm
SAE A 11T-16/32DP Ansi B92 1a 1976

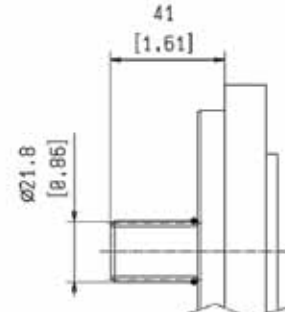

AVAILABLE FROM OCTOBER 2016

code 55 Max torque 200 Nm
SAE A 13T-16/32DP Ansi B92 1a 1976

EO.146.1015.02.001M00



MOUNTING FLANGES

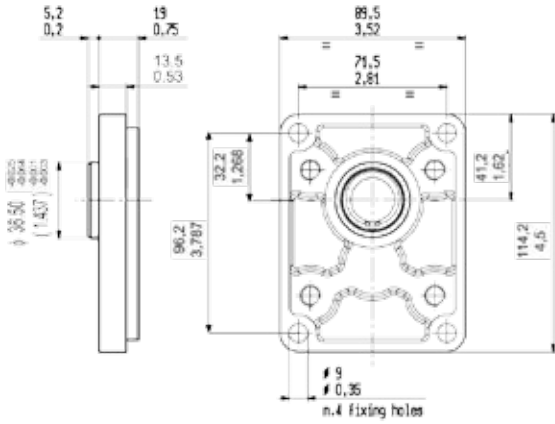

P1 European standard mounting flange

With shaft code 28-62-81-82-85

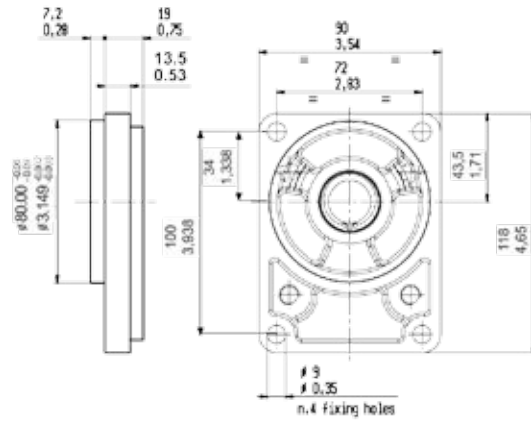

B1 German standard mounting flange

With shaft code 25-62

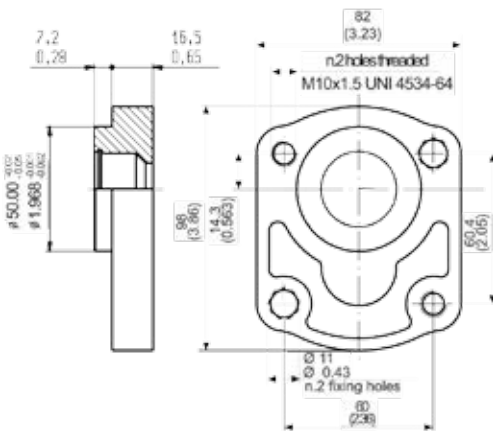

B4 German standard mounting flange

With shaft code 25-62

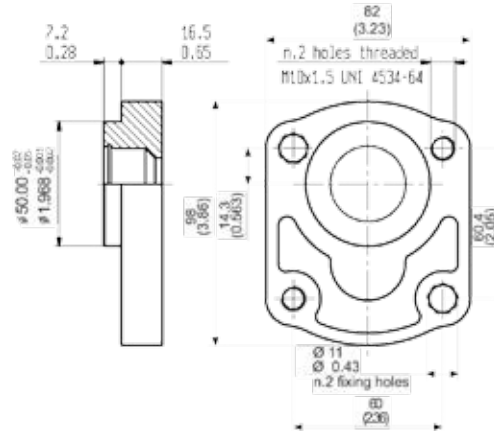

B5 German standard mounting flange

With shaft code 25-62

E0.146.1015.02.00IM00

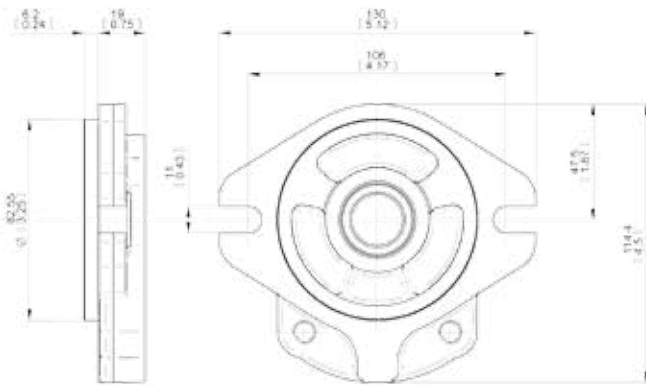

S2

SAE A mounting flange

With shaft code 52-54-82-85

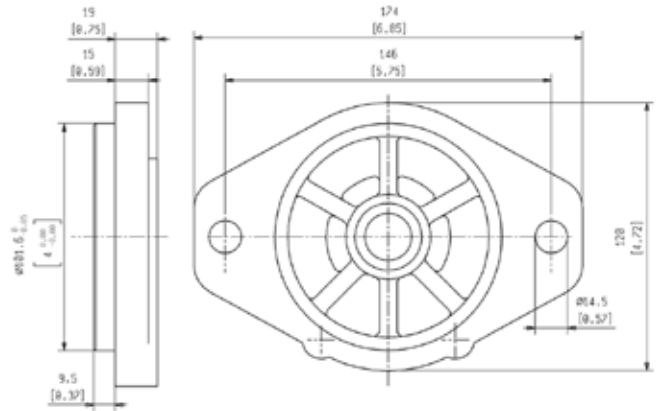

S3

SAE B mounting flange

With shaft code 52-54-82-85

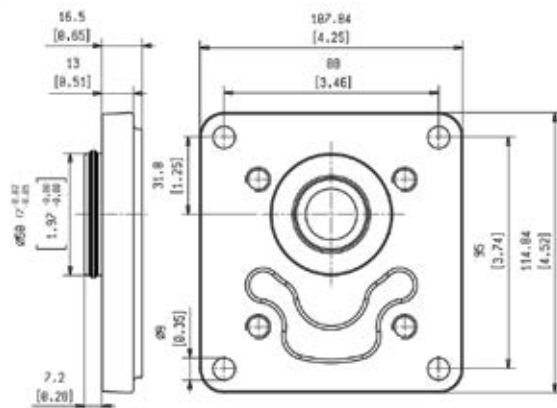

C1

For Iveco engines mounting flange

With shaft code 62

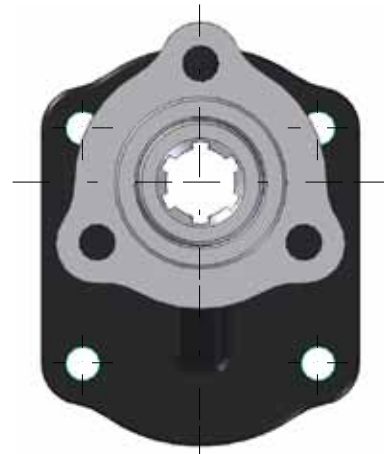

AVAILABLE FROM OCTOBER 2016

3 BOLT UNI 8953 mounting flange

EO.146.1015.02.001M00

OUTRIGGER BEARING

The diagram shows the values of admissible radial loads, in case of parallel axis drag.

The duty life of 3500 - 4000 hours is referred to a typical mobile application, where the use is not continuous for long periods of time.

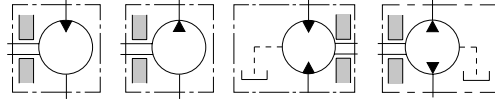

L=Distance between mounting flange and radial force point of application

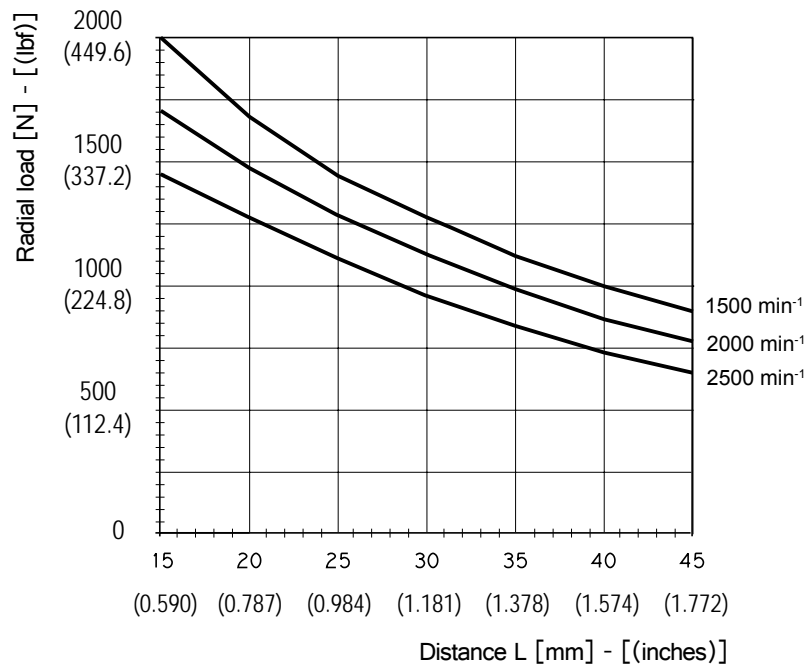
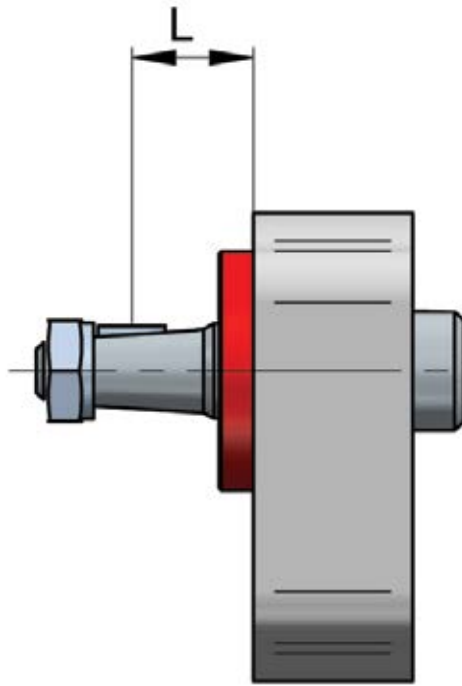

E0.146.1015.02.00IM00



MOUNTING FLANGES WITH OUTRIGGER BEARING SUPPORT

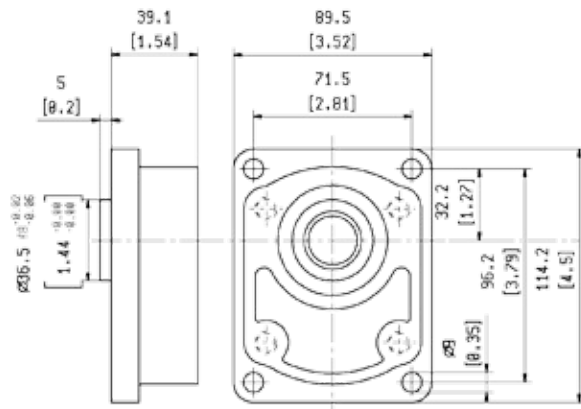

CP European standard mounting flange

With shaft code 28

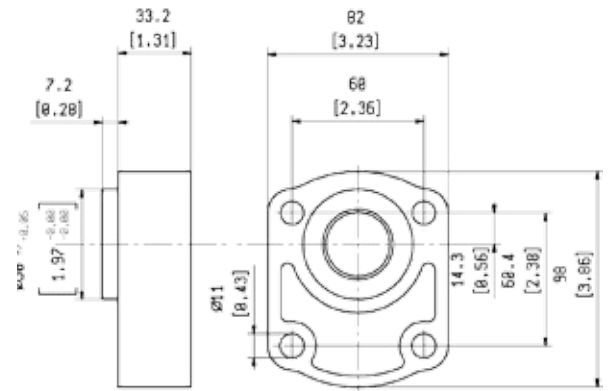

CL For engine endo thermic motors mounting flange

With shaft code 25, 26

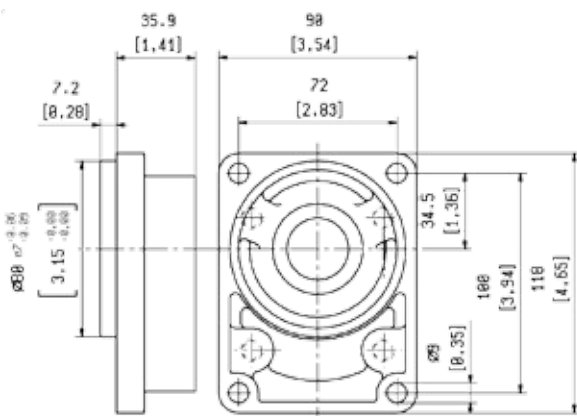

CB German standard mounting flange

With shaft code 25-26

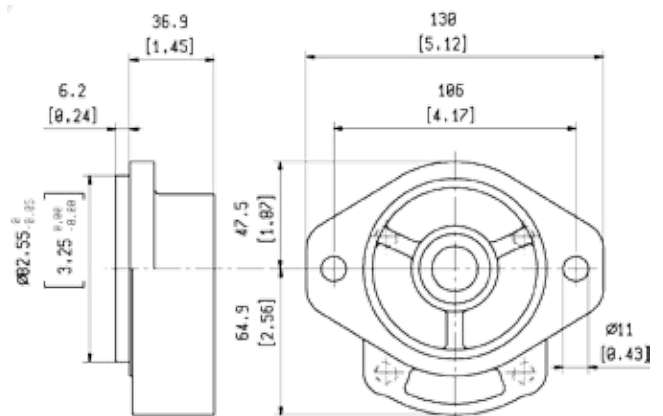

CS SAE A mounting flange

With shaft code 52-54-82-85

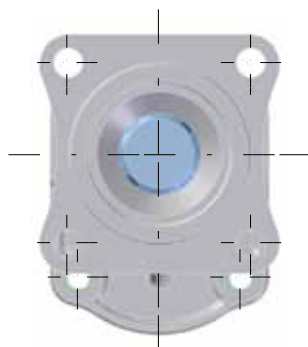

AVAILABLE FROM OCTOBER 2016

Z1 ISO 7653 mounting flange

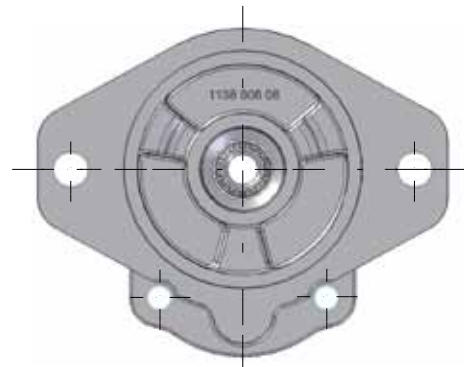

AVAILABLE FROM OCTOBER 2016

CSB SAE B mounting flange

EO.146.1015.02.001M00



REAR COVERS

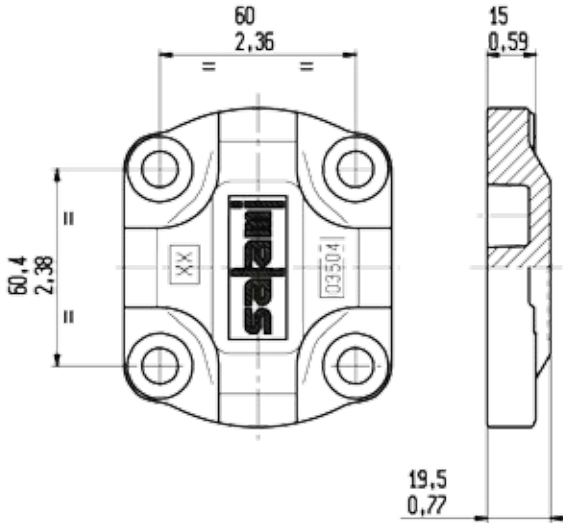

Standard rear cover
for unidirectional pumps and
motors

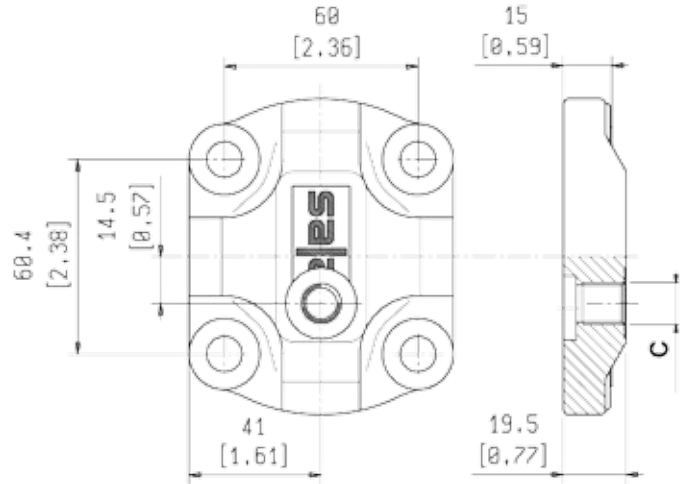

Standard rear cover
for reversible pumps and motors, with external drain ΦC .
For the dimension ΦC please see the table here below

REAR DRAIN

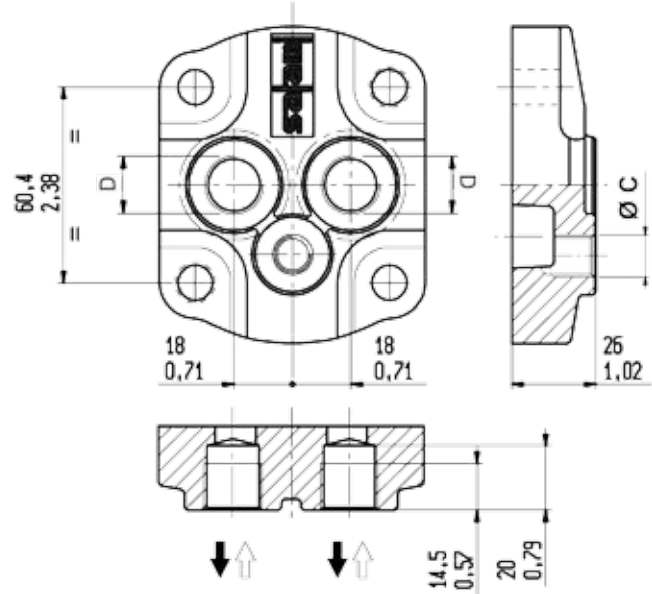
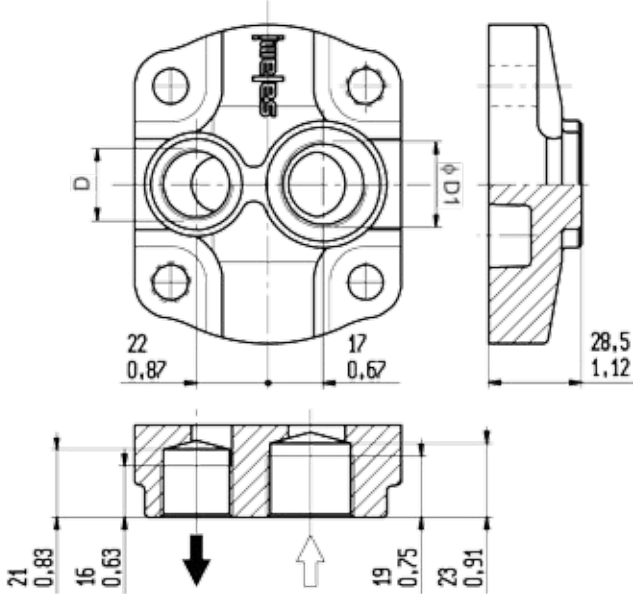

UNIDIRECTIONAL PUMPS AND MOTORS

On request outlet port only.

D	D1
M18x1.5	M26x1.5
7/8-14 UNF-2B (SAE10)	1-1/16-12 UN-2B (SAE12)
G1/2	G3/4

code 1

BIDIRECTIONAL MOTORS

For motors with threaded rear ports until 25 l/min delivery

D	C
M18x1.5	M26x1.5
7/8-14 UNF-2B (SAE10)	7/16-20 UNF-2B (SAE4)
G1/2	G1/4

E0.146.1015.02.00IM00



REAR COVERS WITH INTERNAL AND LATERAL DRAIN

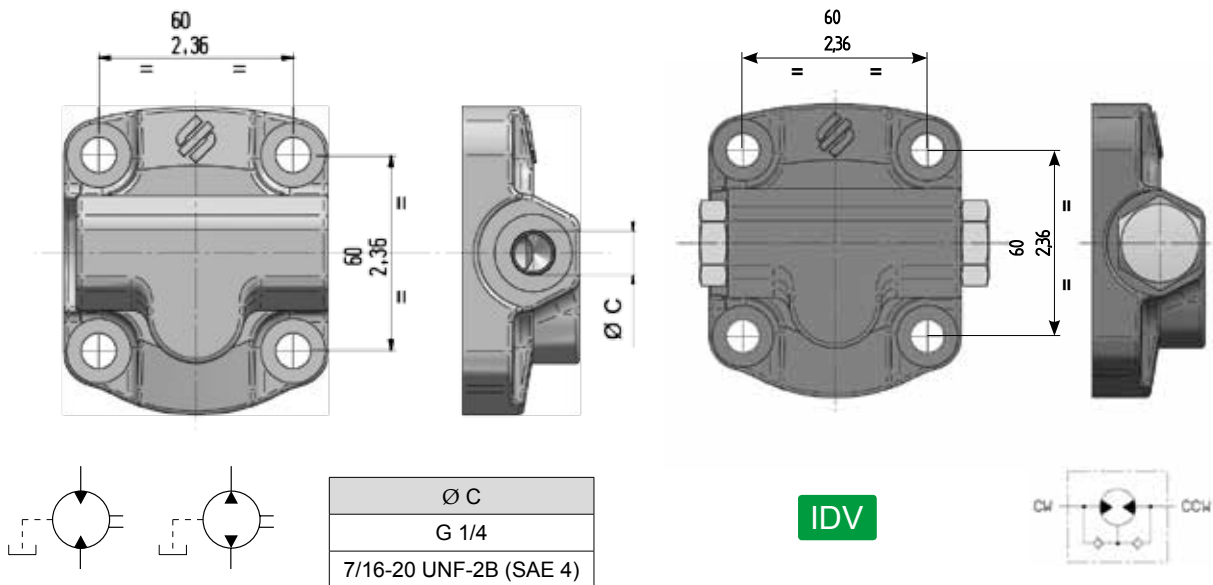

REAR COVERS WITH MAIN RELIEF VALVES

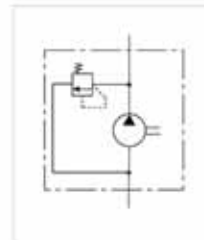
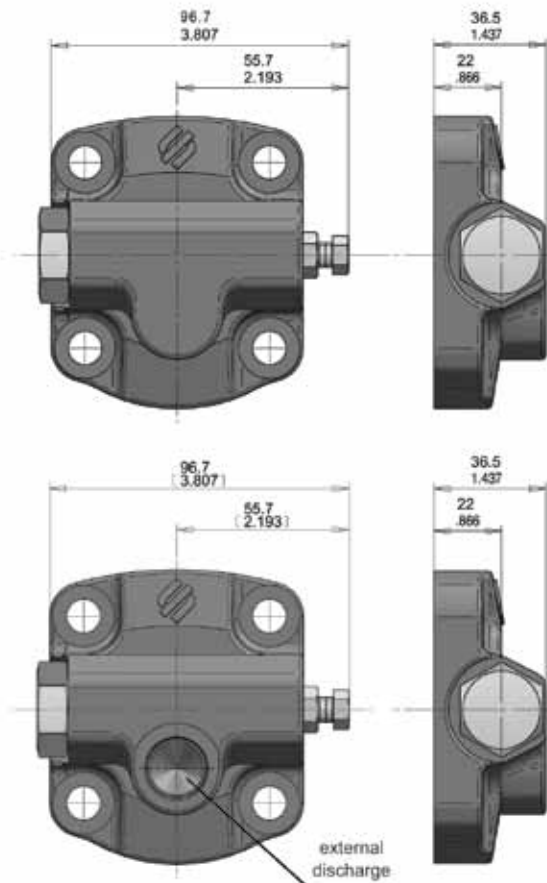

code VS

With main relief valve
with internal exhaust
gallery

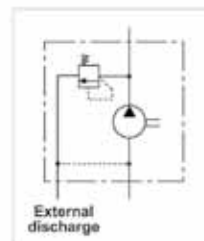

code VSE

For this main relief valve you
can choice four setting
ranges:

- (20 - 50 bar)
- (51 - 75 bar)
- (76 - 150 bar)
- (151 - 220 bar)

D (external discharge)
M 18 x 1.5 (METRIC)
3/4-16 UNF-2B (SAE 8)
G 3/8 (BSPP)

EO.146.1015.02.001M00



PRIORITY FLOW VALVE

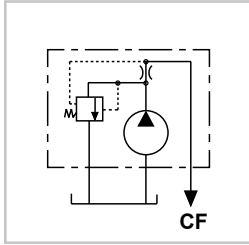

code VR

code VR1

Pressure compensated flow control valve with excess flow to tank

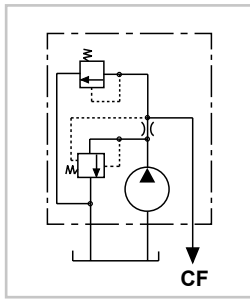

code VRS

code VRS1

Pressure compensated flow control valve with excess flow to tank, with main relief valve on controlled flow line.

CALIBRATED ORIFICE Φ d (mm/inch)	FLOW RATE (l/min - gpm) ± 10%
1.5 / (0.06")	2.5 - (0.66)
2 / (0.08")	4 - (1.06)
2.4 / (0.09")	6 - (1.59)
2.8 / (0.11")	8 - (2.11)
3.1 / (0.12")	10 - (2.64)
3.5 / (0.14")	12.5 - (3.30)
4 / (0.16")	16 - (4.23)
4.4 / (0.17")	20 - (5.28)
4.9 / (0.19")	25 - (6.61)

FLOW CONTROL VALVE (VR-VRS)

3 - Way flow control valve housed in a special cast iron cover which ensures constant flow regardless pump speed and system pressure variations. It can also be supplied with adjustable pressure relief valve whose relieved flow goes into excess pump flow line. In this way the max fluid temperature is lower than obtained if the excess flow returned directly to pump inlet. The flow regulated is determined by the diameter of hole on the threaded dowel (see table).

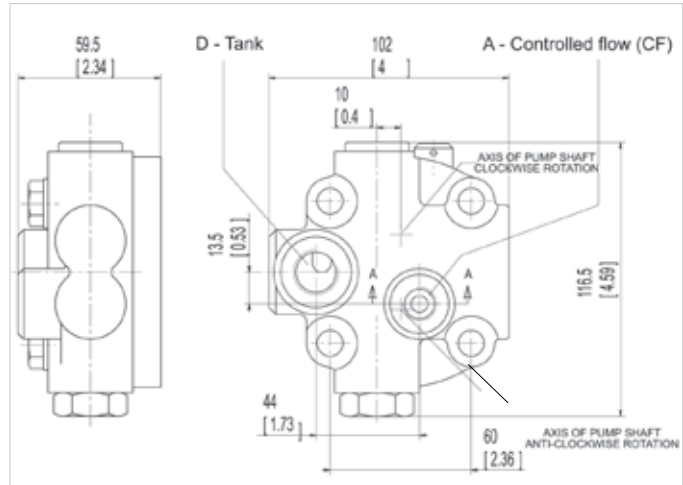

VR - VRS
REAR PORTS

A	D
G 3/8	G 1/2
SAE6 9/16-18 UNF-2B	SAE8 3/4 - 16 UNF - 2B

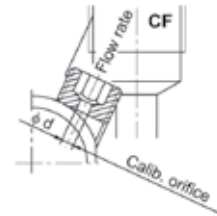

Det. SECT.A-A

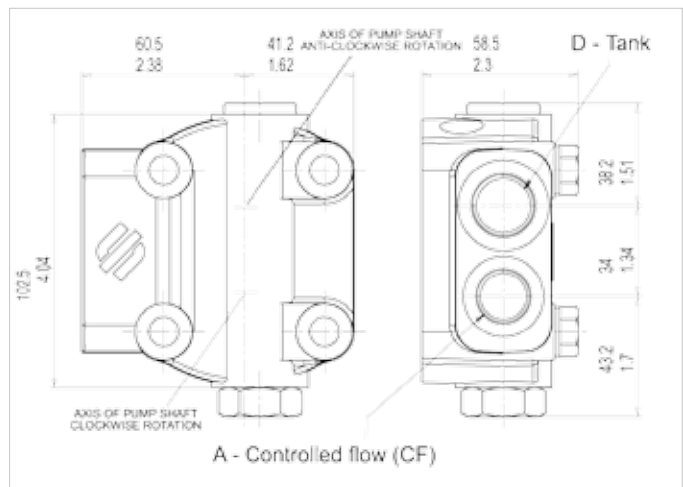

VR1 - VRS1
SIDE PORTS

CF - port

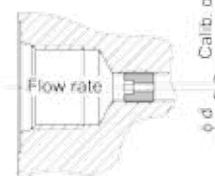

A	D
G 3/8	G 1/2
SAE8 3/4 - 16 UNF - 2B	SAE10 7/8 - 14 UNF - 2B

E0.146.1015.02.00IM00



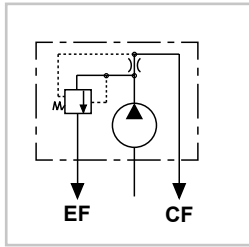

code VP

code VP1

Priority flow valve, excess flow to second actuator.

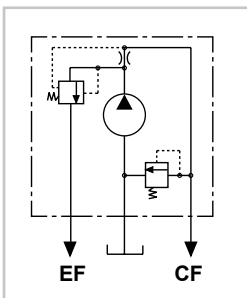

code VPS

code VPS1

Priority flow valve, excess flow to second actuator with pressure relief valve on priority flow line.

CALIBRATED ORIFICE Φ d (mm/inch)	FLOW RATE (l/min - gpm) ± 10%
1.5 / (0.06")	2.5 - (0.66)
2 / (0.08")	4 - (1.06)
2.4 / (0.09")	6 - (1.59)
2.8 / (0.11")	8 - (2.11)
3.1 / (0.12")	10 - (2.64)
3.5 / (0.14")	12.5 - (3.30)
4 / (0.16")	16 - (4.23)
4.4 / (0.17")	20 - (5.28)
4.9 / (0.19")	25 - (6.61)

PRIORITY FLOW VALVE (VP - VPS)

These are basically the same as VR valves differing only because the two flows can be loaded at the same time for supplying two separate circuits defined priority flow remains constant regardless of pump speed and system pressure variations. The second defined excess flow is directly proportional to pump speed. Priority flow is determined by diameter of hole on threaded dowel (see table). The max. pressure of the priority circuit can be limited by valve which relieves into pump suction.

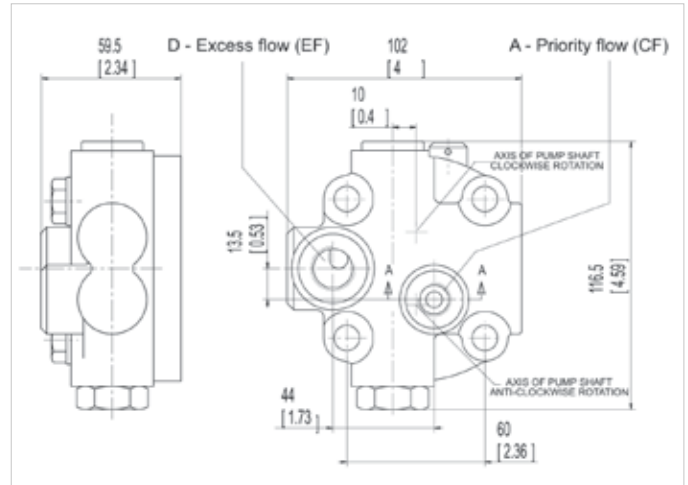

**VP - VPS
REAR PORTS**

A	D
G 3/8	G 1/2
SAE6 9/16-18 UNF-2B	SAE8 3/4 - 16 UNF - 2B



Det. SECTA-A

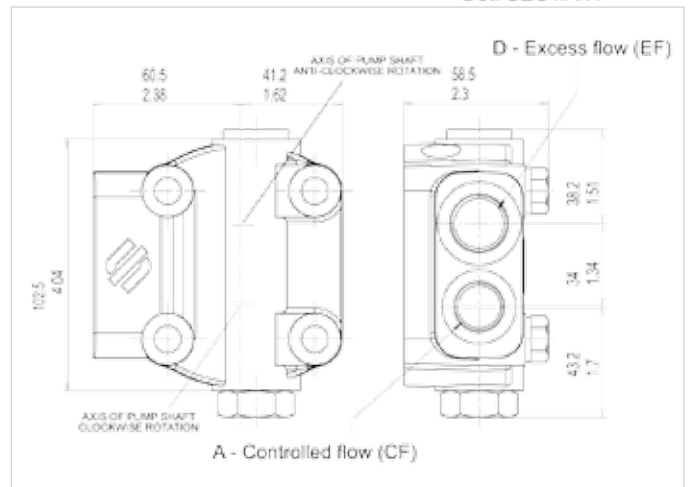

**VP1 - VPS1
SIDE PORTS**

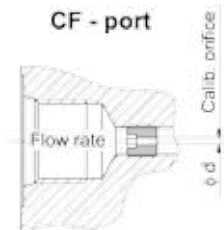

A	D
G 3/8	G 1/2
SAE8 3/4 - 16 UNF - 2B	SAE10 7/8 - 14 UNF - 2B

EO.146.1015.02.001M00



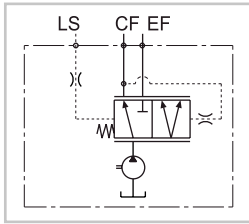

code VPD

code VPD1

Load sensing priority valve with dynamic signal without main relief valve.

CF = Priority flow port
EF = Excess flow port
LS = Load sensing signal port

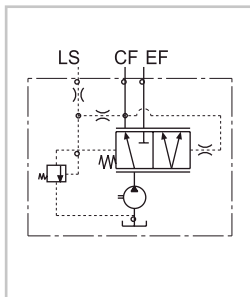

code VPDS

code VPDS1

Load sensing priority valve with dynamic signal with main relief valve.

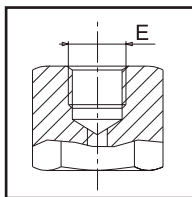

Female fitting

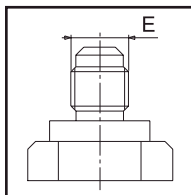

Male fitting

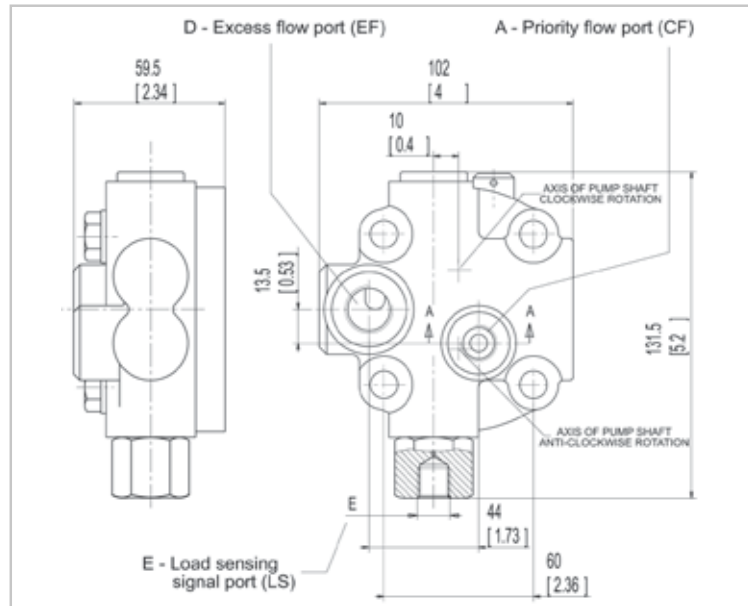

VPD - VPDS
REAR PORTS

Minimum load sensing signal (LS) = 4 bar (28 psi)

A	D	E
G 3/8	G 1/2	G 1/4
SAE6 9/16 - 18 UNF - 2B	SAE8 3/4 - 16 UNF - 2B	SAE4 7/16 - 20 UNF - 2B

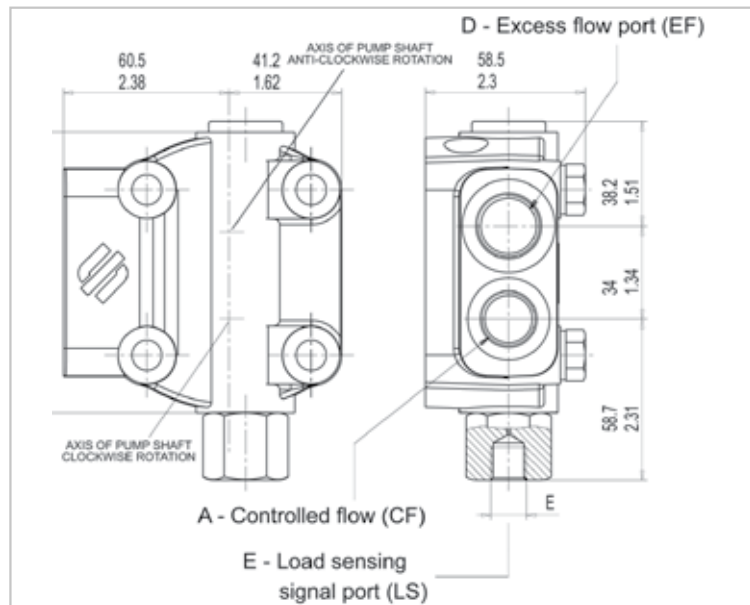

VPD1 - VPDS1
SIDE PORTS

Minimum load sensing signal (LS) = 4 bar (28 psi)

A	D	E
G 3/8	G 1/2	G 1/4
SAE8 3/4 - 16 UNF - 2B	SAE10 7/8 - 14 UNF - 2B	SAE4 7/16 - 20 UNF - 2B

E0.146.1015.02.00IM00



**MULTIPLE GEAR PUMPS
ASSEMBLING DIMENSIONS**

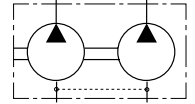
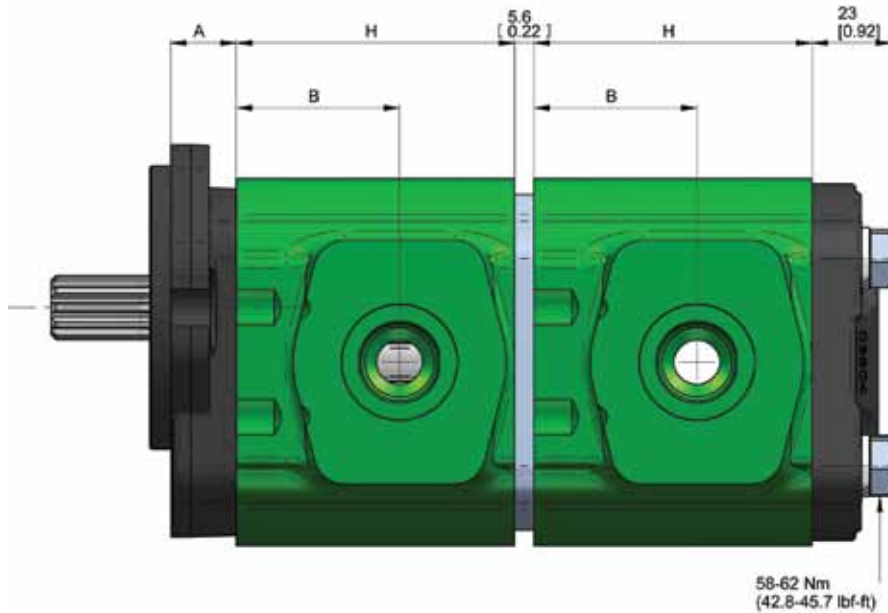

**MULTIPLE
GEAR PUMPS
with inlet port
on each body**

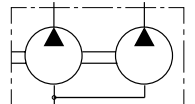

**MULTIPLE
GEAR PUMPS
with common inlet port***

The 2PGE pumps can be easily transformed into front pump in the multiple units. All drive shafts are pre-arranged and have a splined end according DIN 5480. The first unit must always be the same size or bigger than following units. The features and performances are the same of the corresponding single units: only in the case of simultaneous operating you have to verify that the inlet torque is lower than the max. transmissible by the drive shaft.

Type		16	19	22.5	26
Dimension A (flanges B4 - B5 - C1)	mm	16.5			
	in	0.65			
Dimension A (flanges P1 - S2 - B1 - S3)	mm	19			
	in	0.75			
Dimension B	mm	39.5	39.5	47.5	47.5
	in	1.56	1.56	1.87	1.87
Dimension H	mm	67.5	75.6	81	86.8
	in	2.65	2.97	3.19	3.42

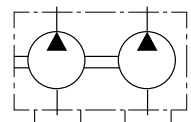
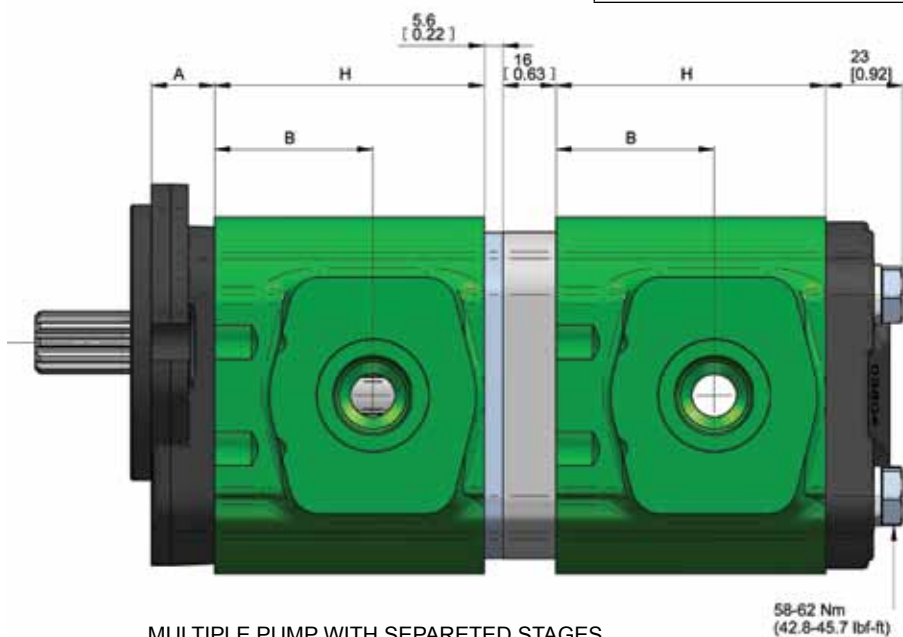

code AS

**MULTIPLE PUMP WITH SEPARATED STAGES
FOR DIFFERENT FLUIDS (2 TANKS)**

EO.146.1015.02.001M00



PUMPS PERFORMANCE CURVES

Performance curves carried out with oil viscosity at 16 cSt and oil temperature at 60°C

2PGE16

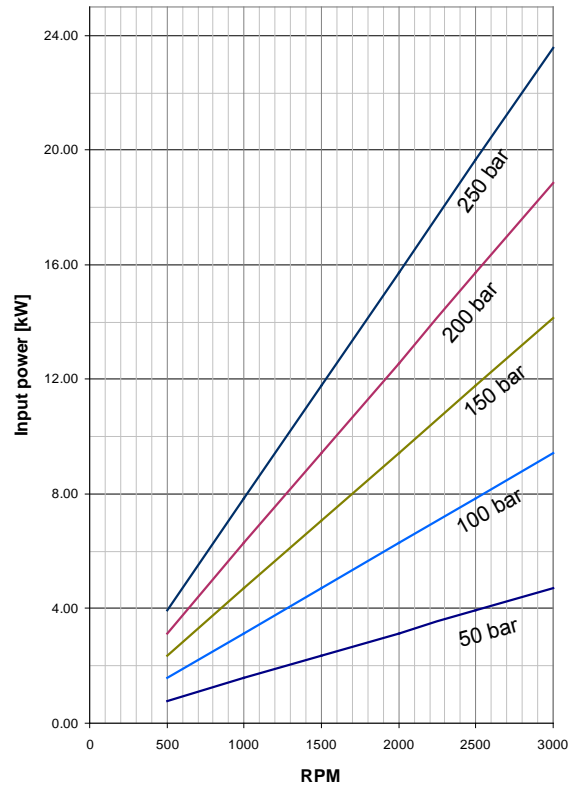
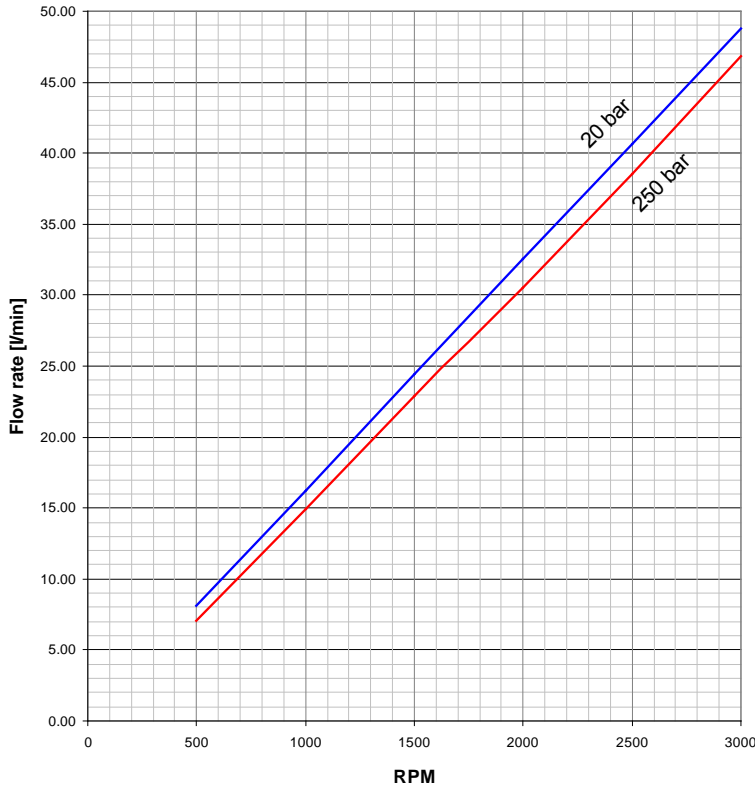

2PGE19

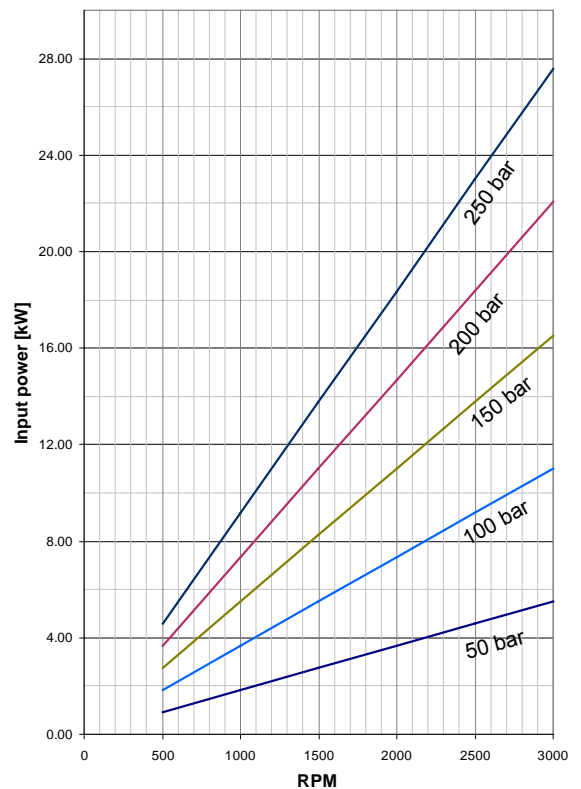
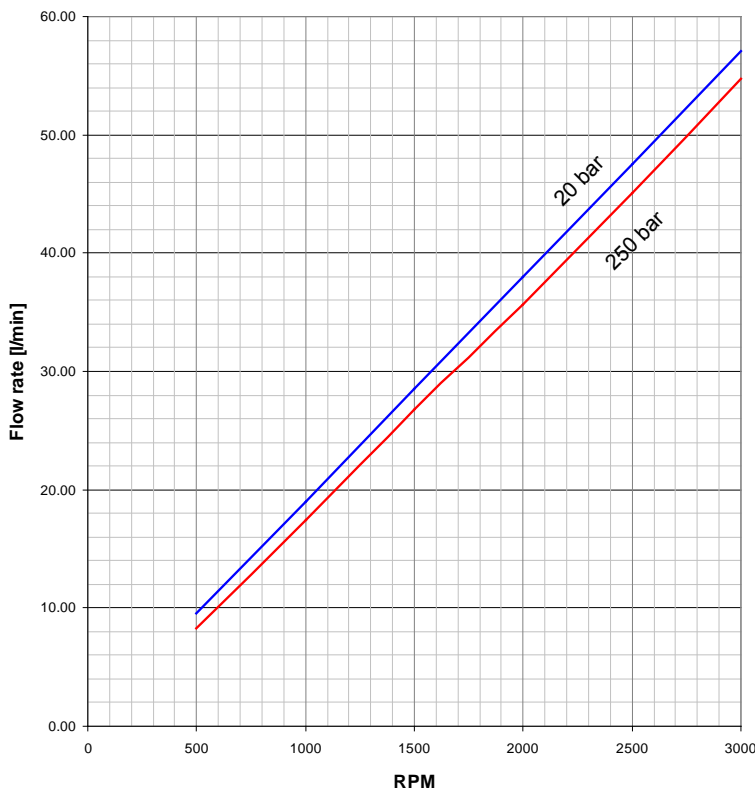

E0.146.1015.02.00IM00



2PGE22.5

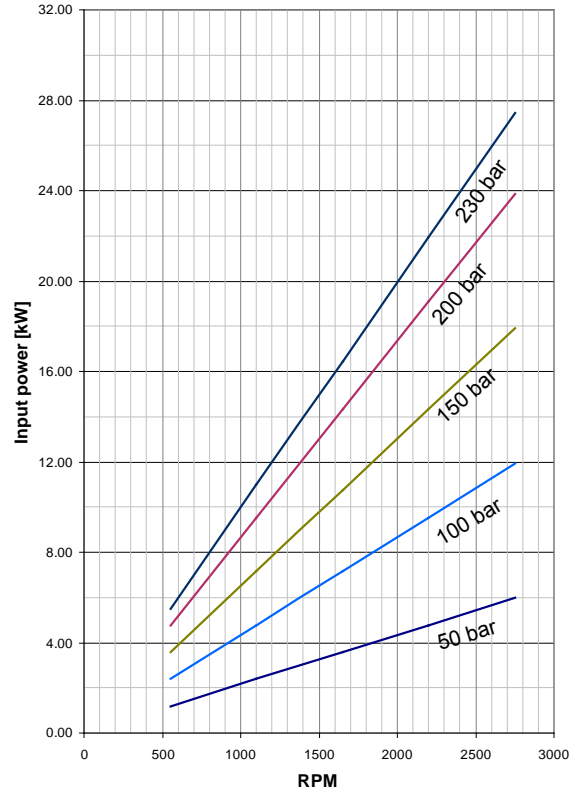
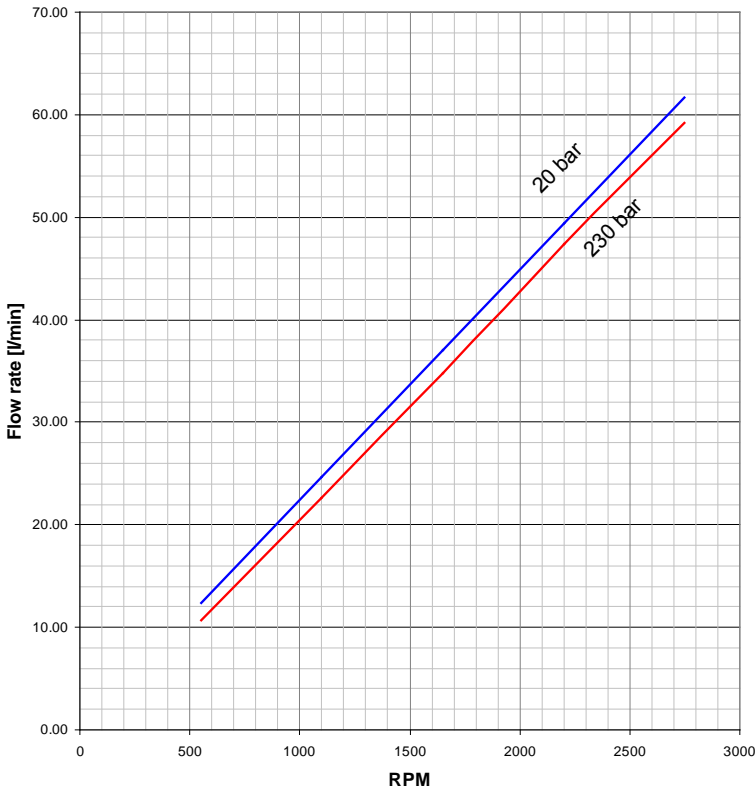

2PGE26

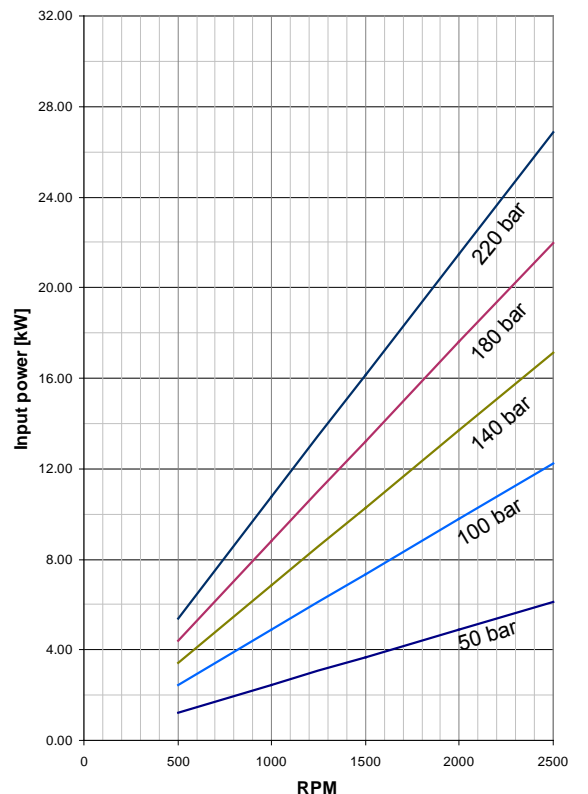
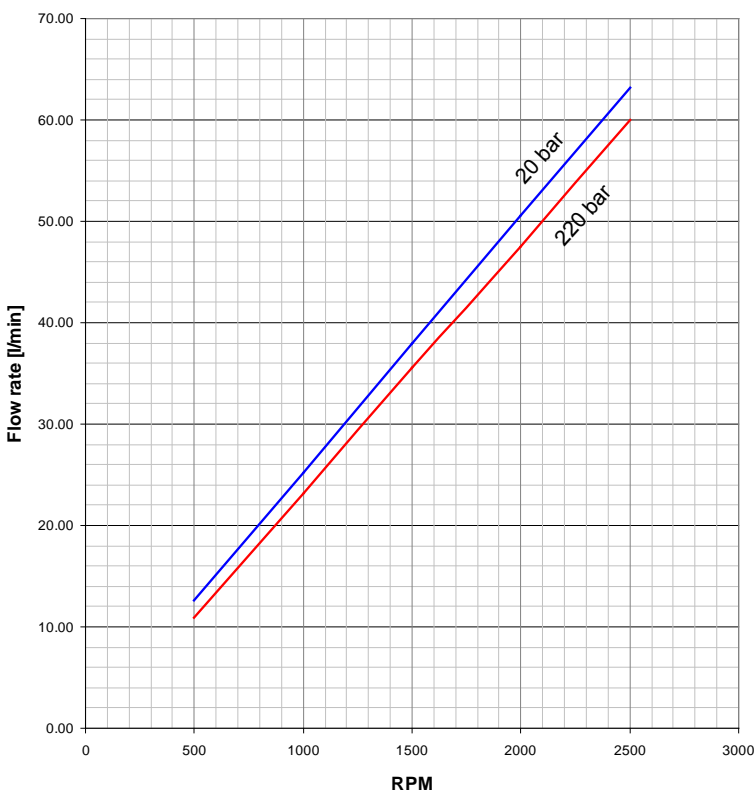

EO.146.1015.02.001M00



MOTORS PERFORMANCE CURVES

Performance curves carried out with oil viscosity at 16 cSt and oil temperature at 60°C

2MGE16

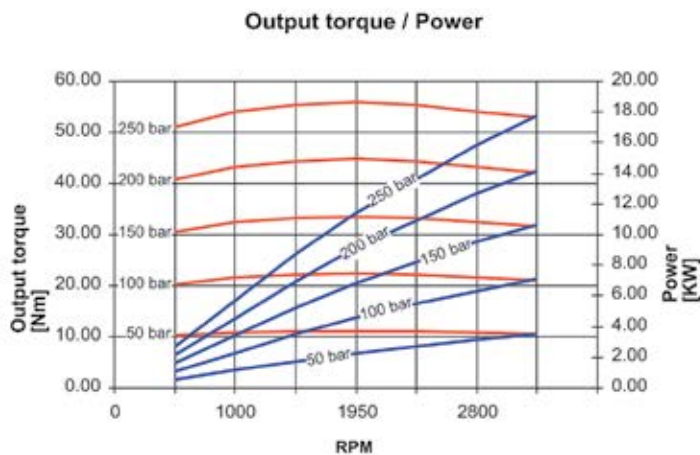
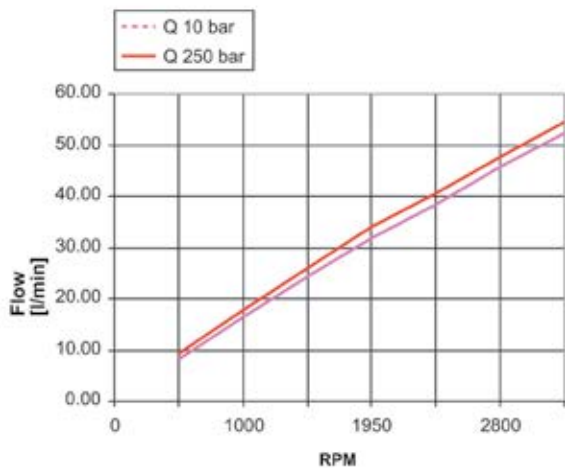

2MGE19

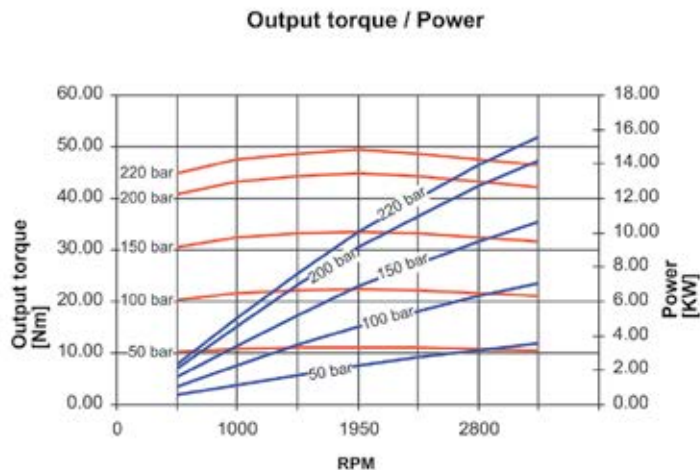
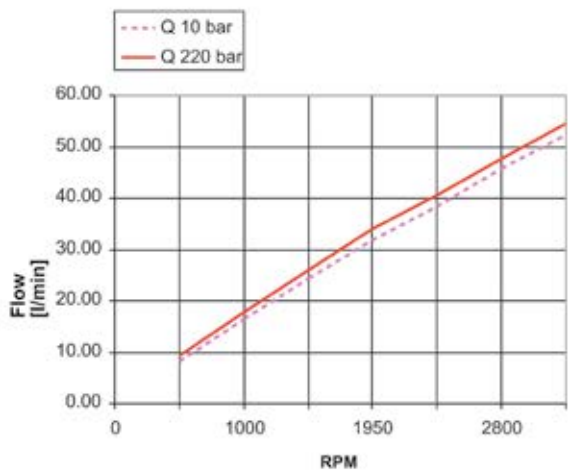

E0.146.1015.02.00IM00



2MGE22.5

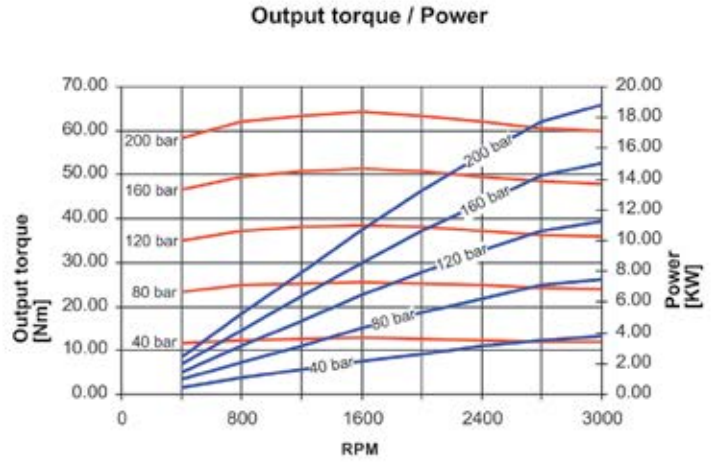
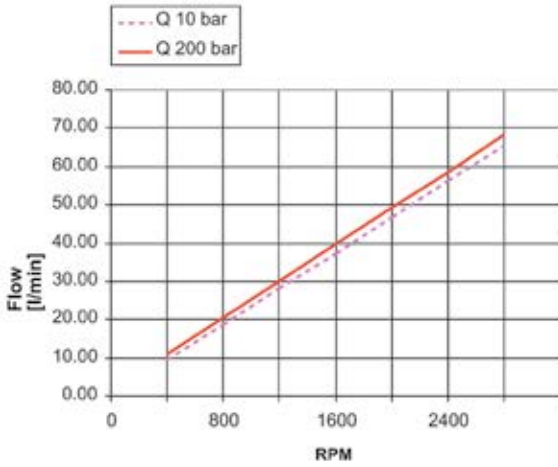

2MGE26

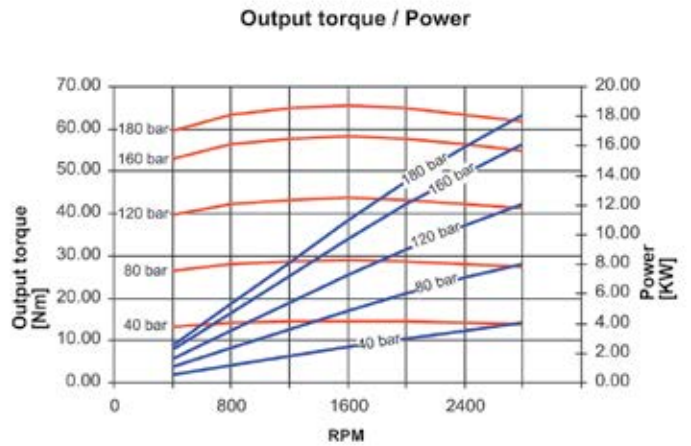
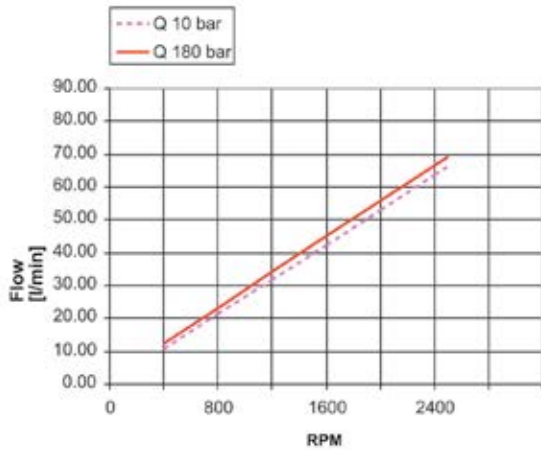

EO.146.1015.02.001M00



SINGLE PUMPS AND SINGLE MOTORS

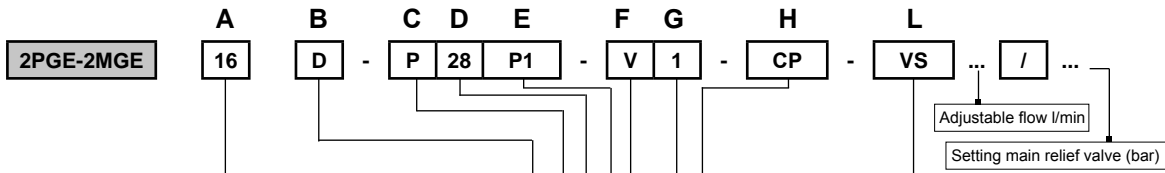

TYPE	A	DISPLACEMENTS	
16	16.6 cm ³ /rev.	1.01 cu.in/rev.	
19	19.4 cm ³ /rev.	1.18 cu.in/rev.	
22.5	22.9 cm ³ /rev.	1.37 cu.in/rev.	
26	25.8 cm ³ /rev.	1.58 cu.in/rev.	

ROTATION	CODES	B
Clockwise	D	
Anti-clockwise	S	
Reversible	R	

PORTS (page 10-12)	CODES	C
Flanged ports european standard	P	
Flanged ports german standard	B	
Flanged ports SAE J518 Metric thread	W	
Flanged ports SAE J518 American standard thread	S	
Threaded ports GAS (BSPP)	G	
Threaded ports SAE (ODT)	R	

DRIVE SHAFT (page 13)	CODES	D
Tapered 1:5	25	
Tapered 1:5 (only for CB)	26	
Tapered 1:8	28	
SAE A splined 9T	52	
SAE A splined 11T	54	
SAE A splined 13T	55	
DIN 5480 internal splined	60	
9 teeth DIN 5482 splined	62	
5/8" SAE A parallel	82	
3/4" SAE A parallel	85	

L	VALVES IN THE COVER (PAGE 20-22)	CODES
	Adjustable main relief valve	VS
	Fixed setting main relief valve	VSE
	Flow regulator with excess flow to tank	VR-VR1
	Like VR with main relief valve	VRS-VRS1
	Priority flow divider with excess flow to 2nd actuator	VP-VP1
	Like VP with main relief valve	VPS-VPS1
	Priority flow divider with Load sensing with dynamic signal	VPD-VPD1
	Load sensing priority valve with dynamic signal with main relief valve	VPDS-VPDS1

H	OUTRIGGER BEARING (page 17)	CODES
	European standard	CP
	For engine endothermic motors	CL
	German standard	CB
	SAE A	CS

G	PORTS POSITION	CODE
	Lateral ports standard	
	Rear ports (page 18)	1

F	SEAL	CODE
	Buna standard	
	Viton	V

E	MOUNTING FLANGES (page 14-15)	CODES
	European standard	P1
	German standard Ø80	B1
	German standard Ø50	B4-B5
	SAE A 2 bolts	S2
	SAE B 2 bolts	S3
	4 bolts for Iveco motor	C1

Order example 2PGE 19D, ports SAE (R), drive shaft (52), mounting flange (S2) with valve in the cover (VPS 12.5 l/min) and pressure relief valve setting 180 bar: 2PGE 19D-R52 S2-VPS12.5/180

E0.146.1015.02.00IM00



MULTIPLE PUMPS

2PGE
 A 19 / 16
 B D -
 C P
 D 28
 E P1 -
 F V
 G AS
 H 1 -
 I CP -
 L VS
 ... / ...
 Adjustable flow l/min
Setting main relief valve (bar)

TYPE	A	DISPLACEMENTS	
16	16.6 cm ³ /rev.	1.01 cu.in./rev.	
19	19.4 cm ³ /rev.	1.18 cu.in./rev.	
22.5	22.9 cm ³ /rev.	1.37 cu.in./rev.	
26	25.8 cm ³ /rev.	1.58 cu.in./rev.	

ROTATION		CODES	B
Clockwise		D	
Anti-clockwise		S	

PORTS (page 10-12)		CODES	C
Flanged ports european standard		P	
Flanged ports german standard		B	
Flanged ports SAE J518 Metric thread		W	
Flanged ports SAE J518 American standard thread		S	
Threaded ports GAS (BSPP)		G	
Threaded ports SAE (ODT)		R	

DRIVE SHAFT (page 13)		CODES	D
Tapered 1:5		25	
Tapered 1:5 (only for CB)		26	
Tapered 1:8		28	
SAE A splined 9T		52	
SAE A splined 11T		54	
SAE A splined 13T		55	
DIN 5480 internal splined		60	
9 teeth DIN 5482 splined		62	
5/8" SAE A parallel		82	
3/4" SAE A parallel		85	

VALVES IN THE COVER (PAGE 20-22)		CODES
Adjustable main relief valve		VS
Fixed setting main relief valve		VSE
Flow regulator with excess flow to tank		VR-VR1
Like VR with main relief valve		VRS-VRS1
Priority flow divider with excess flow to 2nd actuator		VP-VP1
Like VP with main relief valve		VPS-VPS1
Priority flow divider with Load sensing with dynamic signal		VPD-VPD1
Load sensing priority valve with dynamic signal with main relief valve		VPDS-VPDS1

OUTRIGGER BEARING (page 17)		CODES
European standard		CP
For engine endothermic motors		CL
German standard		CB
SAE A		CS

PORTS POSITION		CODE
Lateral ports standard		
Rear ports (page 18)		1

SUCTION PORTS		CODES
Common suction		UA*
Separated stages		AS

SEAL		CODE
Buna standard		
Viton		V

MOUNTING FLANGES (page 14-15)		CODES
European standard		P1
German standard Ø80		B1
German standard Ø50		B4-B5
SAE A 2 bolts		S2
SAE B 2 bolts		S3
4 bolts for Iveco motor		C1

*UA: this type of multiple pump is a Salami standard multiple pump which has only one inlet port opened, all the other inlet port are closed.
In case of common suction, the code 1 - 2 or 3, correspond to the body where inlet is located.

Example to order a tandem pump with common suction: 2PGE 19/16D - R54S2-UA1
Example to order a triple pump with main relief in the rear pump: 2PGE 22.5/19/16D - R54S2 - VS175

EO.146.1015.02.00IM00



ROTATION CHANGING INSTRUCTIONS FOR UNITS

Before starting, be sure that the pump is cleaned externally as well as the working area to avoid that particles dangerous for pump working can find their way into the pump. Pump represented is a clockwise rotation pump. To obtain an anti_clockwise rotation read carefully the following instructions.

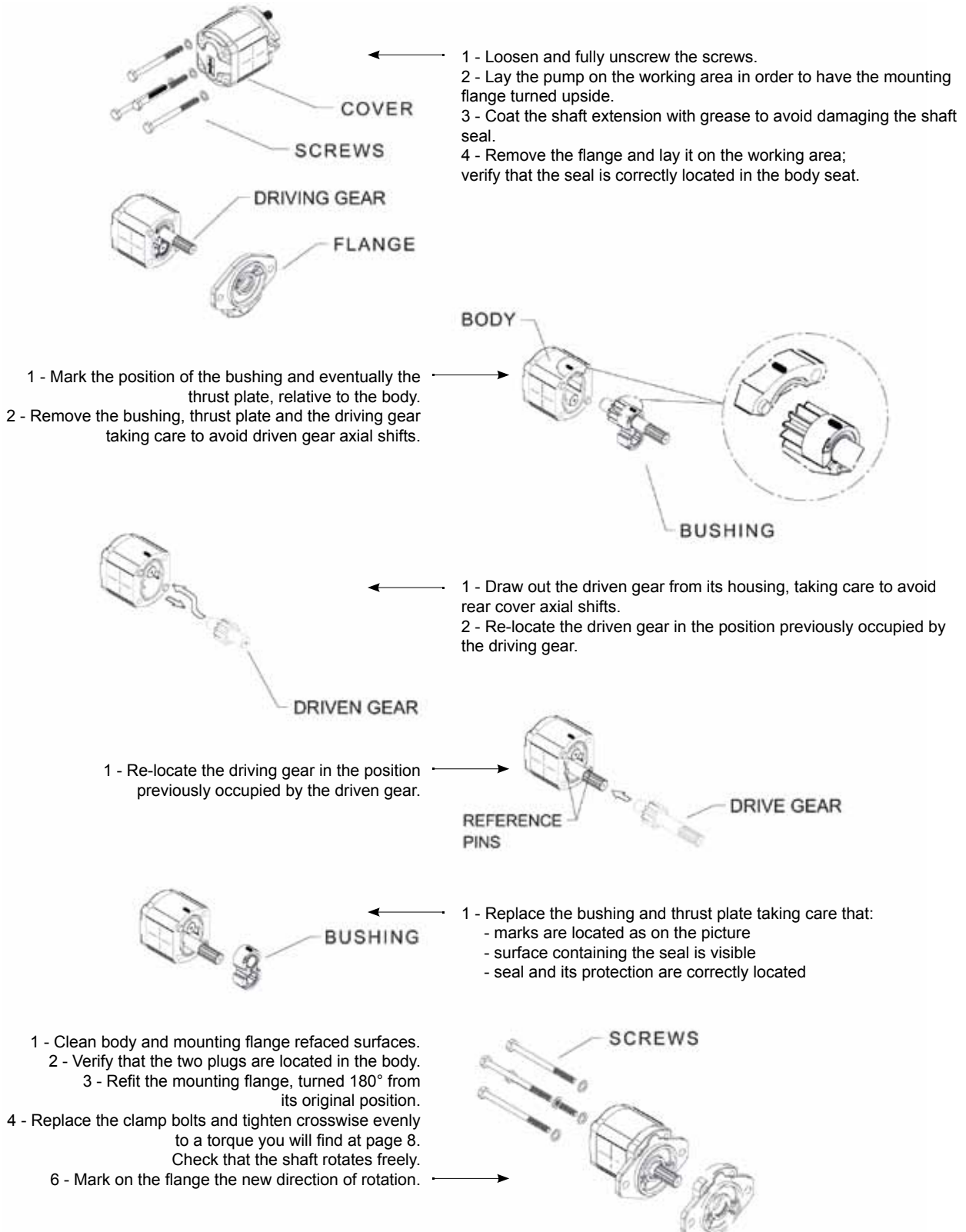

E0.146.1015.02.00IM00



You can find our most up to date “STANDARD SALES CONDITIONS” on our website.

Potete trovare le nostre più aggiornate “CONDIZIONI DI VENDITA STANDARD” sul nostro sito.

www.salami.it

T. +39 059 387 411

sales@salami.it

Watch our tutorials on our official youtube channels



Salami Fluid Power
Salami Fluid Power World
Salami Fluid Power France
Salami Fluid Power España
Salami Fluid Power Deutsch

Salami S.p.a.

Via Emilia Ovest 1006
41121 Modena (Italy)
T. +39 059 387 411
F. +39 059 387 639
sales@salami.it

SALAMI ESPAÑA

Poligono Industrial Armenteres
C/Primer de Maig, 18, Nave 4
08980 San Feliu de Llobregat
Barcelona
T. +34 93 6327 288
F. +34 93 6667 826
info@salamispain.com

SALAMI FRANCE

22, rue Louis Saillant
69120 Vaulx en Velin
Lyon
T. +33 04 7880 9941
F. +33 04 7880 4264
e.pasian@salami.fr

SALAMI HYDRAULICS N.A INC

Loop Road
Baldwinsville
NY 13027 USA
T. +1 315 295 2363
F. +1 315 295 2364
info@salamihydraulics.com