

Series 25

- Available in various configurations
 - 25 – Standard, 2 piece construction
 - TP25 – Tandem, 2 & 3 Place
 - NP25 & NTP25 – “New” series, 3 piece construction, in single, double, and triple sections.
 - PB25 – Piggy-back design – allowing for additional pumps.
- Constructions:
 - Aluminum – For excellent power to weight ratio.
 - or
 - Cast iron – for extra durability.*
- Journal bearings for long life and good over-hung load capability
- Buna-N Seals are standard for petroleum and glycol based fluids “Viton™” seals are optional.
- Pressure balanced plates for greater efficiency.

* Cast iron is not available on all models. Consult factory for availability

Viton is a trademark of the DuPont Co.

Series 25 Seal Kits

MODEL	ASSEMBLY DRAWING	SHAFT SEAL	WHERE USED	SHAFT SEAL KIT	SOFT GOODS KIT
25	47925	14145	#1, 2, 5 shafts	15757	14731
V25	47924	14145	#1, 2, 5 shafts	14722	15760
TP25 2-PLACE	47944	14241	#6, 7, 8, 9 shafts	13871	15775
TP25 3-PLACE	47935	14241	#6, 7, 8, 9 shafts	14810	15780
NP25	60059	14145	#1, 2 shafts	15757	15766
NTP25	60056	14145	#1 shaft	15757	15778
		14241	#7, 9 shafts	13871	15779
VNTP25	62338	14145	#1 shaft	14722	16284
		14241	#7, 9 shafts	14810	16285
PB25	49527	14145	#1 shaft	15757	15773
		14241	#7, 9 shafts	13871	15774
VPB25	61528	14145	#1 shaft	14722	15783
		14241	#7,9 shafts	14810	15784

M25

ALL

VITON 0013215 0015761
 0015762 0015763

Model 25



Description Gear Pumps
 Flow Range To 208 GPM (787.3 LTR.)
 Displacements . To 19.22 C.I.R. (314.96 CC's/REV.)
 Maximum Pressure to 3000 PSI (207 BAR)
 Maximum Speed to 2500 RPM
 Rotation A or C
 Bearings Journal
 Construction Aluminum
 Cast Iron Available—Consult Factory

Performance Data

PUMP MODEL	SECTION SIZE	DISPLACEMENT/REVOLUTION (Theoretical)					MAXIMUM PRESSURE		MAXIMUM SPEED
		US Gallons	Cubic Inches	Liters	Cubic Centimeters	Imperial Gallons	PSI	BAR	RPM
25	300	.0262	6.05	.0992	99.142	.022	3000	207	2500
25	350	.0306	7.07	.1158	115.857	.025	3000	207	2500
25	400	.0350	8.08	.1324	132.408	.029	3000	207	2500
25	450	.0394	9.10	.1491	149.123	.033	3000	207	2500
25	500	.0435	10.05	.1647	164.690	.036	2500	172	2500
25	550	.0479	11.06	.1812	181.241	.040	2500	172	2500
25	660	.0581	13.42	.2200	219.915	.048	2500*	172*	2500
25	770	.0671	15.50	.2540	254.400	.056	2500*	172*	2500
25	950	.0832	19.22	.3150	314.960	.069	2500*	172*	2500

Available with Viton Seals for use with phosphate ester base fluids. All data based on SAE 10W oil at 150°F.
 Cast-iron not available on all models. Consult factory for availability.
 *Consult factory for application approval.

CAUTION: "Inlet vacuum" should not exceed 5" Hg at normal operating speed and temperature.
 Operation of pumps in excess of 5" Hg requires factory approval.

When sizing pumps, refer to the performance charts in the back of the catalog to determine the volumetric efficiency and input horsepower requirements.

How To Order

'A' denotes counterclockwise rotation
 'C' denotes clockwise rotation
 When viewed from drive shaft end

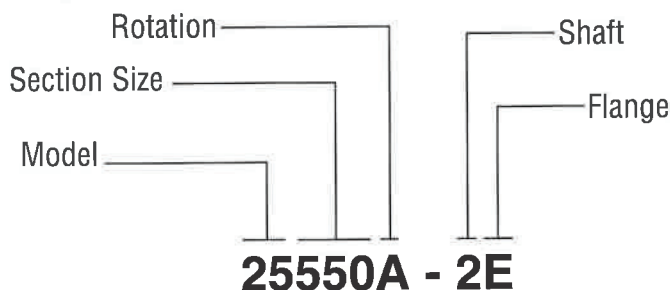

Note: Add prefix 'V' to pump model number (V25) when ordering pumps with Viton Seals for use with phosphate ester base fluids.
 Add prefix 'FP' to pump model number (FP25) when ordering pumps with cast iron construction.

Shafts Available

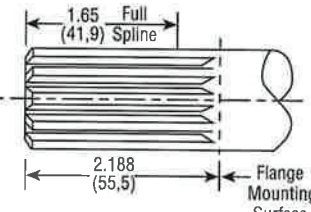
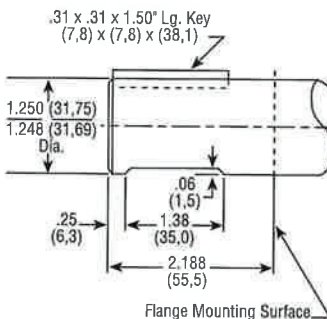
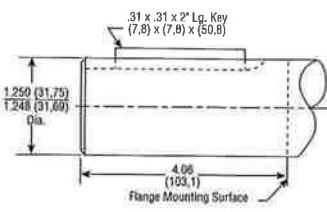
<p>1 SAE 'C' 1-1/4" 14 Tooth Spline Flat Root Side Fit Torque limit 655 Lbs. Ft. (888,0 Nm)</p>  <p>Spline Data Diametral Pitch 12/24 Pressure Angle 30° No. Of Teeth 14</p>	<p>2 SAE 'C' 1-1/4" 14 Straight Shaft Torque limit 655 Lbs. Ft. (888,0 Nm)</p> 	<p>5 1-1/4" Straight Shaft Torque limit 655 Lbs. Ft. (888,0 Nm)</p> 
---	---	--

Mounting Flanges Available

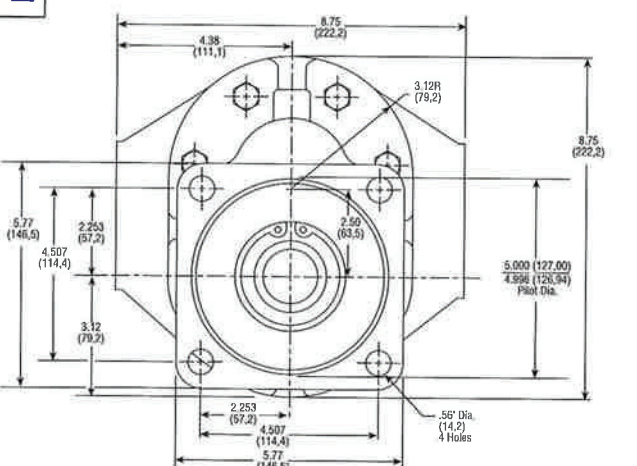
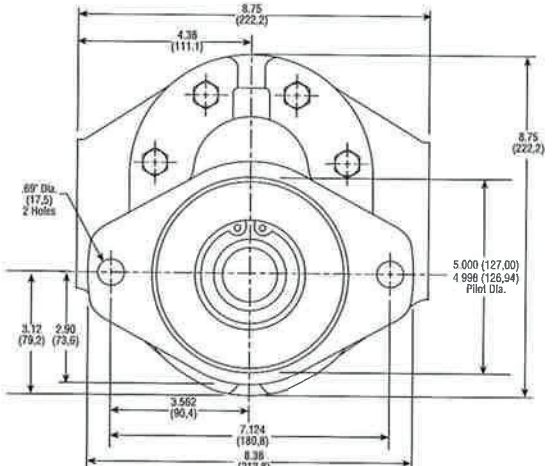
<p>E SAE 'C' 4-Bolt</p> 	<p>F SAE 'C' 2-Bolt</p> 
--	--

Dimensional Data

Mounting Dimensions

PUMP SIZE	For 'C' 2-Bolt & 'C' 4-Bolt Flg.		SAE 4-Bolt Conn. Port		Conn. Hole Dia.		Shipping Weights (Approx.)	
	A	B	Suction	Disc.	Suction	Disc.	lbs.	kgs.
25300	5.06 (128,5)	8.81 (223,7)	2"	1-1/4"	2.00 (50,8)	1.25 (31,7)	41	18.60
25350	5.06 (128,5)	8.81 (223,7)	2"	1-1/4"	2.00 (50,8)	1.25 (31,7)	42	19.05
25400	5.06 (128,5)	8.81 (223,7)	2"	1-1/4"	2.00 (50,8)	1.25 (31,7)	43	19.50
25450	5.06 (128,5)	8.81 (223,7)	2"	1-1/4"	2.00 (50,8)	1.25 (31,7)	44	19.96
25500	4.88 (123,9)	8.63 (219,2)	2-1/2"	1-1/2"	2.50 (63,5)	1.50 (38,1)	45	20.41
25550	5.06 (128,5)	8.81 (223,7)	2-1/2"	1-1/2"	2.50 (63,5)	1.50 (38,1)	45	20.41
25660	5.31 (34,8)	9.06 (230,1)	2-1/2"	1-1/2"	2.50 (63,5)	1.50 (38,1)	46	20.87
25770	5.56 (141,2)	9.31 (236,4)	2-1/2"	1-1/2"	2.50 (63,5)	1.50 (38,1)	48	21.77
25950	6.21 (157,7)	9.95 (252,7)	3"	2"	3.00 (76,2)	2.00 (50,8)	49	22.23

SAE 4-Bolt Connector Ports

Size	C	D	E	F	G	J	
						'A' Rotation	'C' Rotation
1-1/4"	.59 (14,9)	1.188 (30,1)	1.15 (29,2)	2.313 (58,7)	7/16-14NC	1.50 (38,1)	1.00 (25,4)
1-1/2"	.70 (17,7)	1.406 (35,7)	1.37 (34,7)	2.750 (69,8)	1/2-13NC	1.50 (38,1)	1.00 (25,4)
2"	.84 (21,3)	1.688 (42,8)	1.53 (38,8)	3.062 (77,7)	1/2-13NC	1.50 (38,1)	1.00 (25,4)
2-1/2"	1.00 (25,4)	2.000 (50,8)	1.75 (44,4)	3.500 (88,9)	1/2-13NC	1.50 (38,1)	1.00 (25,4)
3"	1.21 (30,7)	2.438 (61,9)	2.09 (53,0)	4.188 (106,3)	5/8-11NC	1.50 (38,1)	1.00 (25,4)

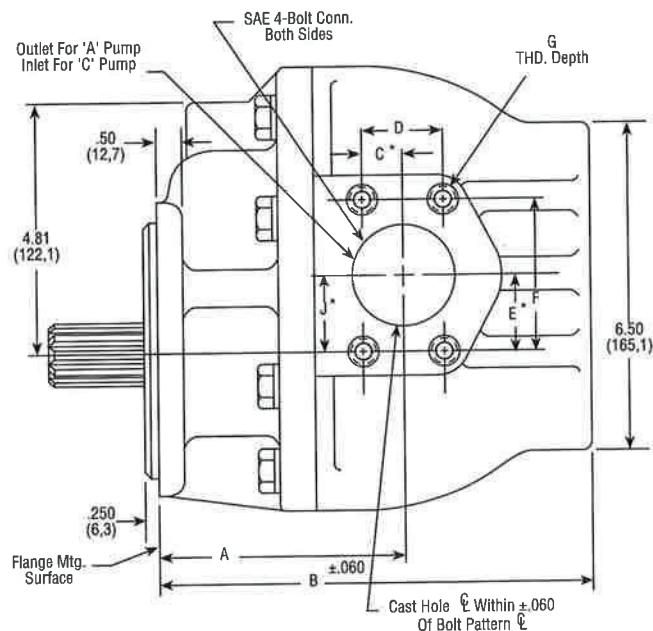

* These dimensions locate C of bolt pattern only

SAE 4-Bolt NPT Connectors are available. See Accessory Section



